

x37 Kernel 1    x37 Kernel 2    x37 boot prom    x37 dma    x37 kalender och NVRAM    x37 MAC    x37 led driver    x37 kernel control    x37 kernel control 2    x37 clock    x37 kernel control 3    x37 dram interface 1    x37 dram interface 2    x37 dram interface 3    x37 dram interface 4    x37 Address latch

File: x37kernel1.kicad\_sch    File: x37kernel2.kicad\_sch    File: x37boot\_prom.kicad\_sch    File: x37dma.kicad\_sch    File: x37\_kalender\_nvram.kicad\_sch    File: x37\_mac.kicad\_sch    File: x37\_led\_driver.kicad\_sch    File: x37\_kernel\_control.kicad\_sch    File: x37\_kernel\_control\_2.kicad\_sch    File: x37\_clock.kicad\_sch    File: x37\_kernel\_control\_3.kicad\_sch    File: x37\_dram\_interface\_1.kicad\_sch    File: x37\_dram\_interface\_2.kicad\_sch    File: x37\_dram\_interface\_3.kicad\_sch    File: x37\_dram\_interface\_4.kicad\_sch    File: x37\_address\_latch.kicad\_sch

x37 Bank 0    x37 Bank 1    x37 Bank 2    x37 Bank 3    x37 Coor Bank 0-1    x37 Coor Bank 2-3    x37 serial 1    x37 serial 2    x37 floppy interface    x37 floppy interface 2    x37 memory parser    x37 sasi interface    x37 sasi interface 2    x37 sasi interface 3    x37 pulls    x37 connector 1    x37 connector 2    x37 connector 3    x37 connector 4

File: x37\_bank\_0.kicad\_sch    File: x37\_bank\_1.kicad\_sch    File: x37\_bank\_2.kicad\_sch    File: x37\_bank\_3.kicad\_sch    File: x37\_coor\_bank\_0\_1.kicad\_sch    File: x37\_coor\_bank\_2\_3.kicad\_sch    File: x37\_serial\_1.kicad\_sch    File: x37\_serial\_2.kicad\_sch    File: x37\_floppy\_interface.kicad\_sch    File: x37\_floppy\_interface\_2.kicad\_sch    File: x37\_memory\_parser.kicad\_sch    File: x37\_sasi\_interface.kicad\_sch    File: x37\_sasi\_interface\_2.kicad\_sch    File: x37\_sasi\_interface\_3.kicad\_sch    File: x37\_pulls.kicad\_sch    File: x37\_connector\_1.kicad\_sch    File: x37\_connector\_2.kicad\_sch    File: x37\_connector\_3.kicad\_sch    File: x37\_connector\_4.kicad\_sch

x37 power ic    x37 power ic2

File: x37\_power\_ic.kicad\_sch    File: x37\_power\_ic2.kicad\_sch

Todo

x37 fix for check



File: x37\_fix\_for\_check.kicad\_sch

Sheet: /		
File: x37.kicad_sch		
<b>Title:</b>		
Size: A3	Date:	Rev:
KiCad E.D.A.    kicad 6.0.7-f9a2dced07-116-ubuntu22.04.1		Id: 1/39

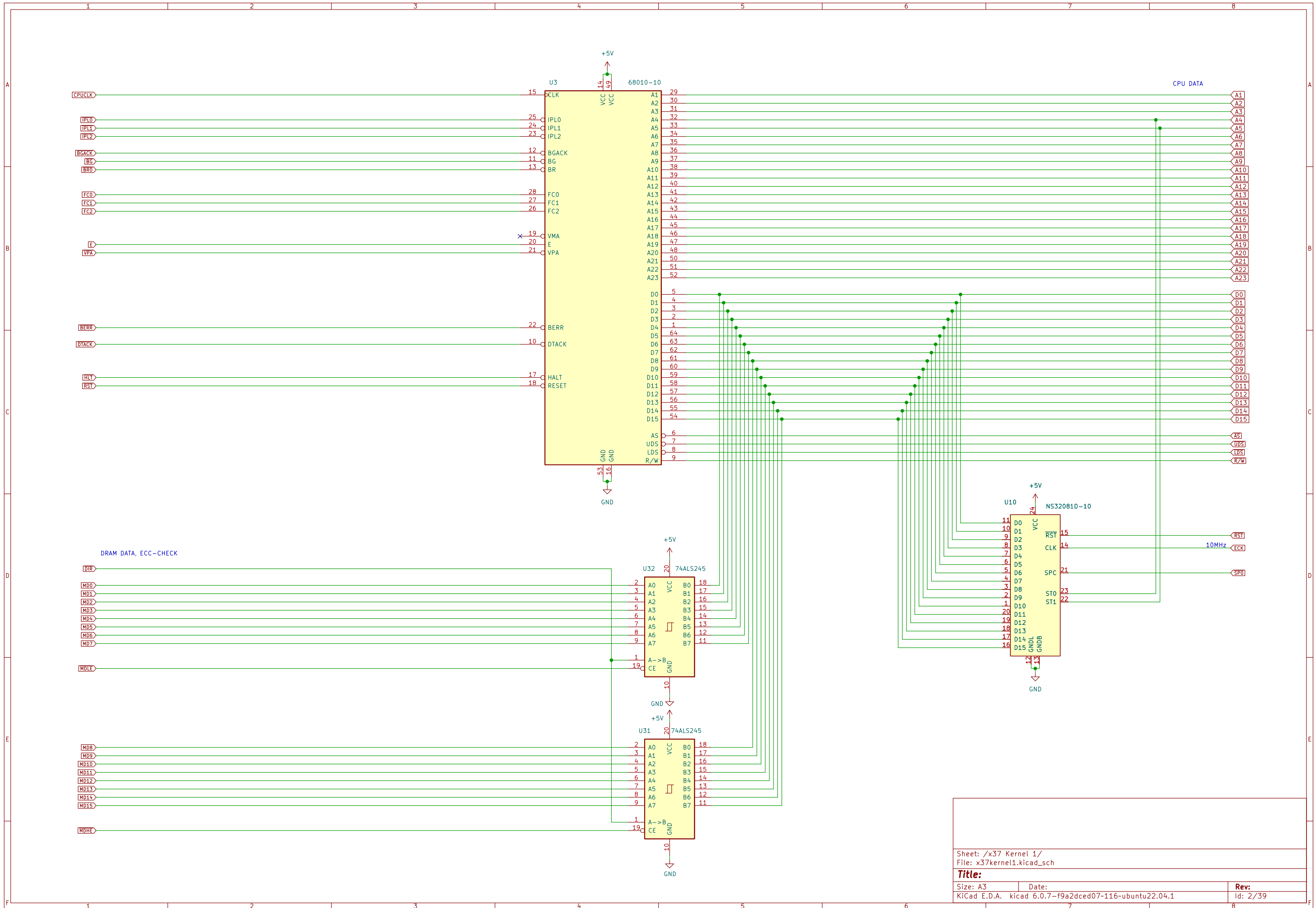

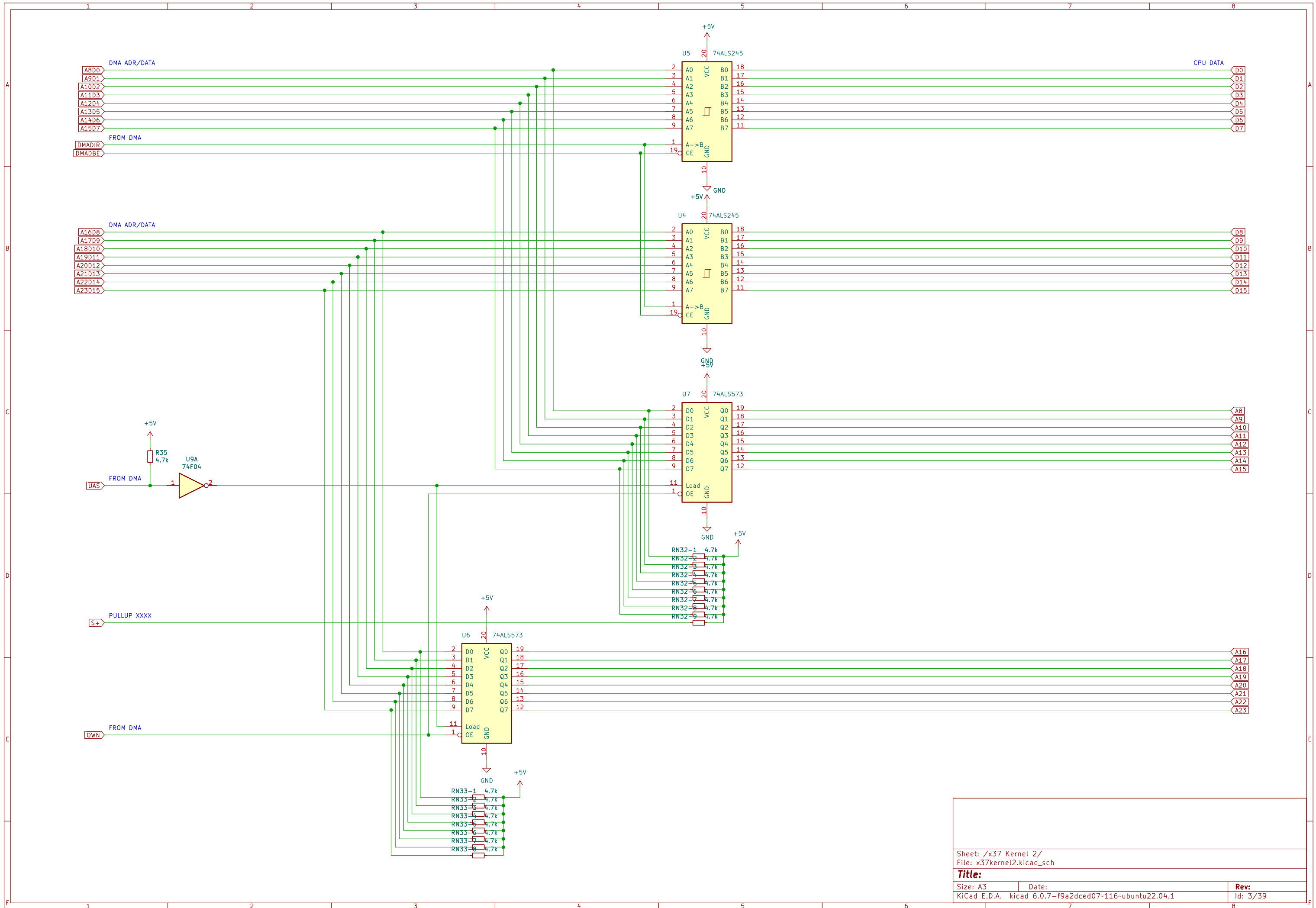

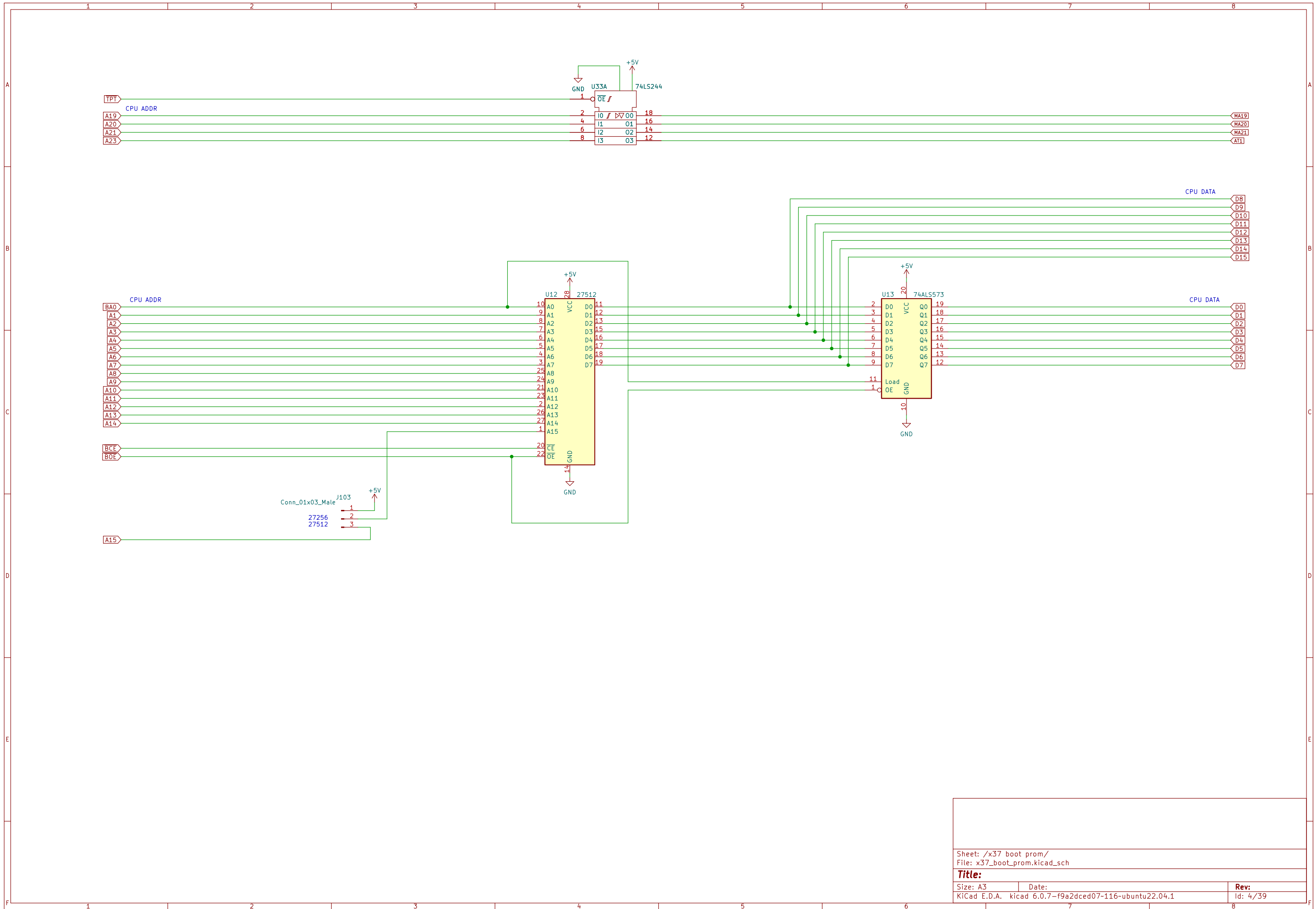

Sheet: /x37 boot prom/  
 File: x37\_boot\_prom.kicad\_sch

<b>Title:</b>		
Size: A3	Date:	Rev:
KiCad E.D.A. kicad 6.0.7-f9a2dced07-116-ubuntu22.04.1		Id: 4/39

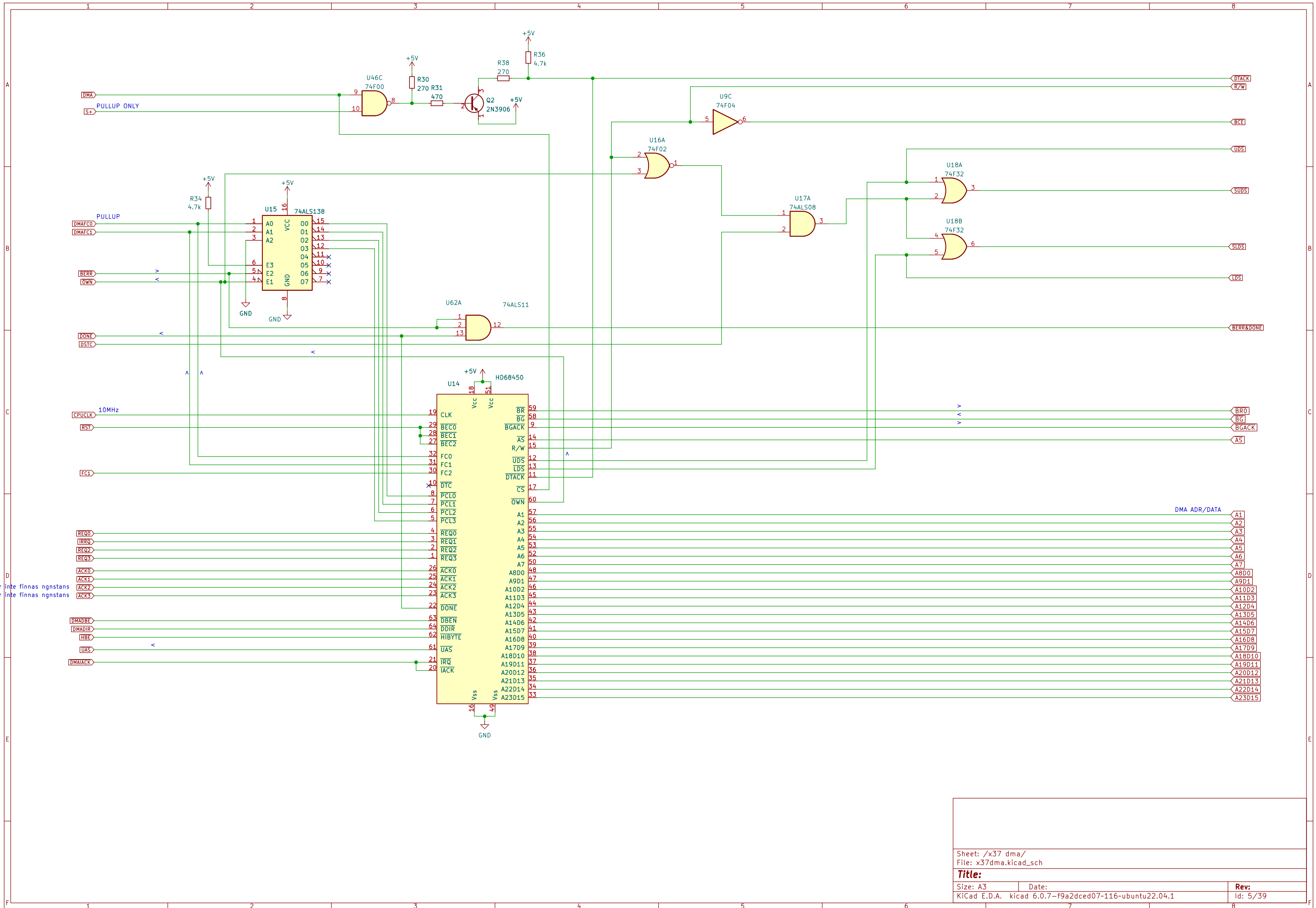

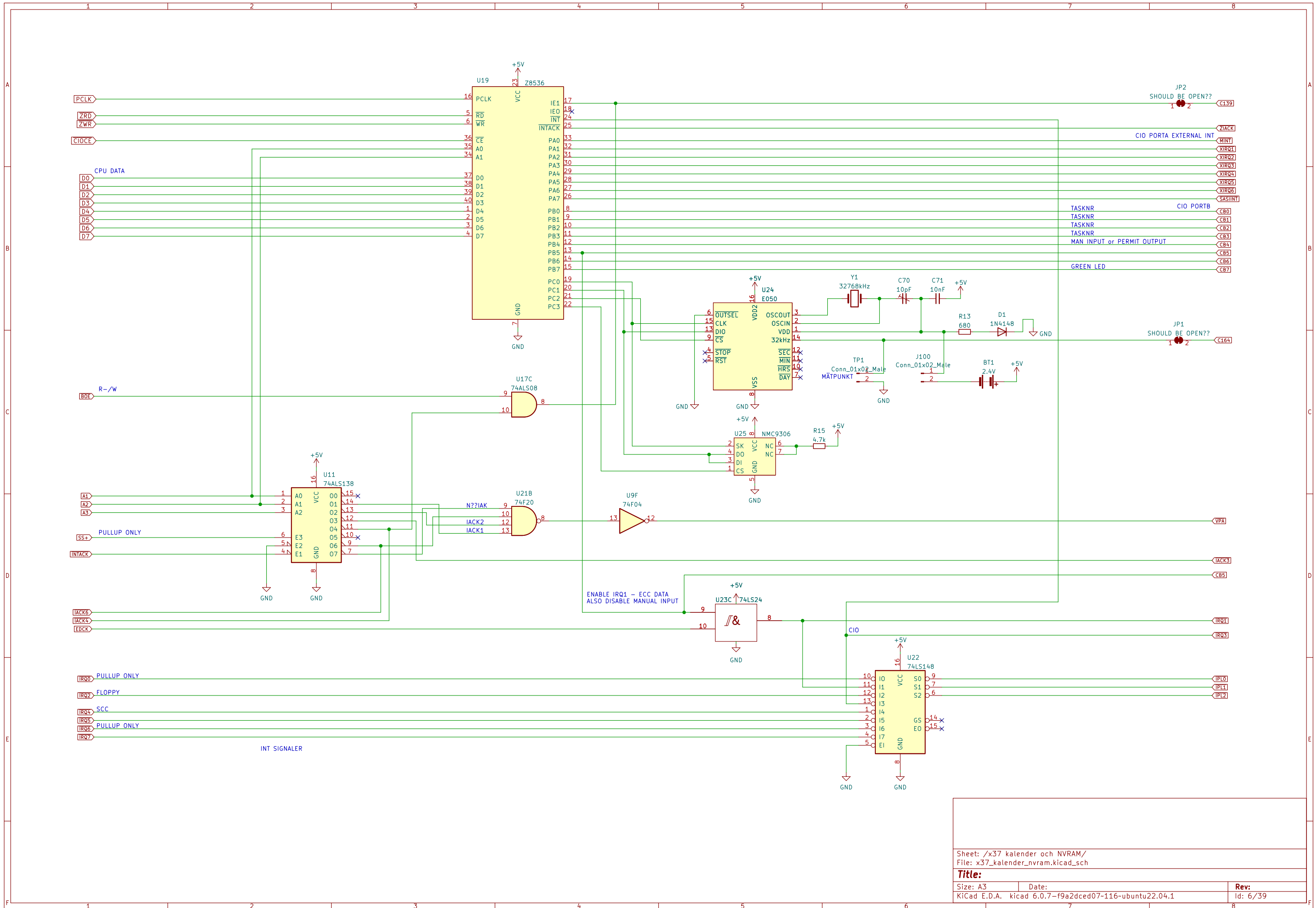

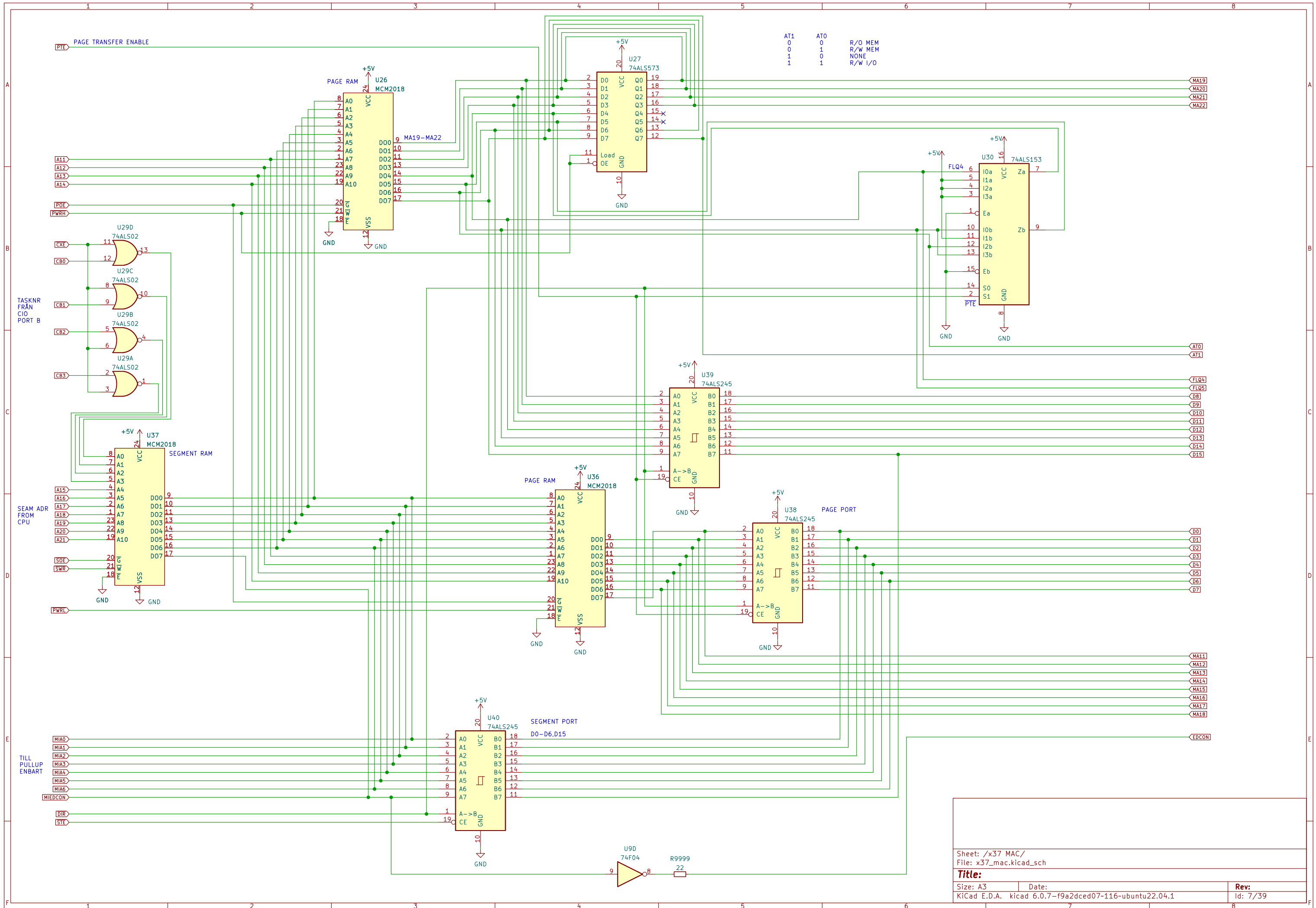

AT1	AT0	R/O MEM
0	0	R/W MEM
1	1	NONE
1	1	R/W I/O

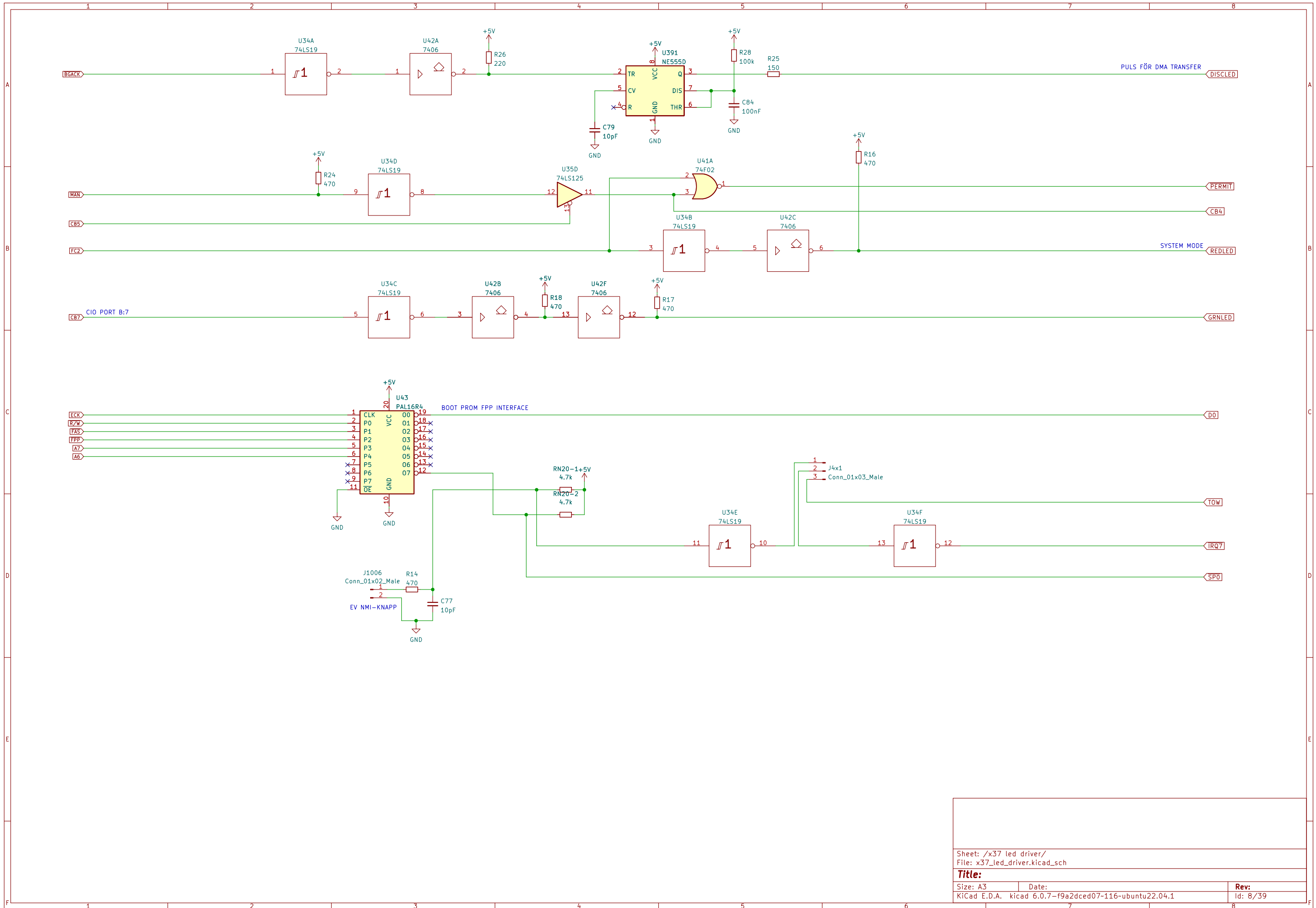

Sheet: /x37 led driver/ File: x37_led_driver.kicad_sch		
<b>Title:</b>		
Size: A3	Date:	Rev:
KiCad E.D.A. kicad 6.0.7-f9a2dced07-116-ubuntu22.04.1		Id: 8/39



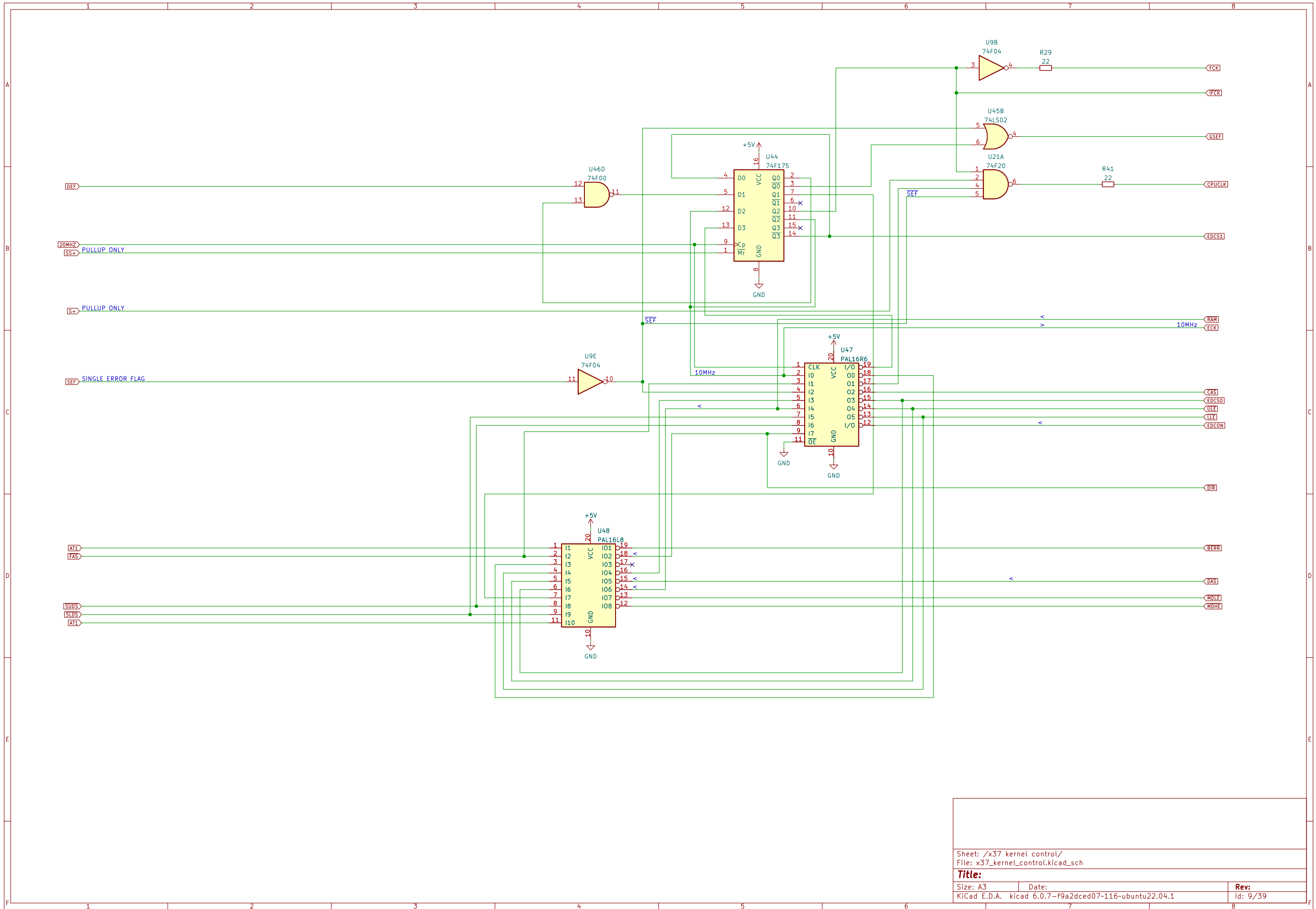

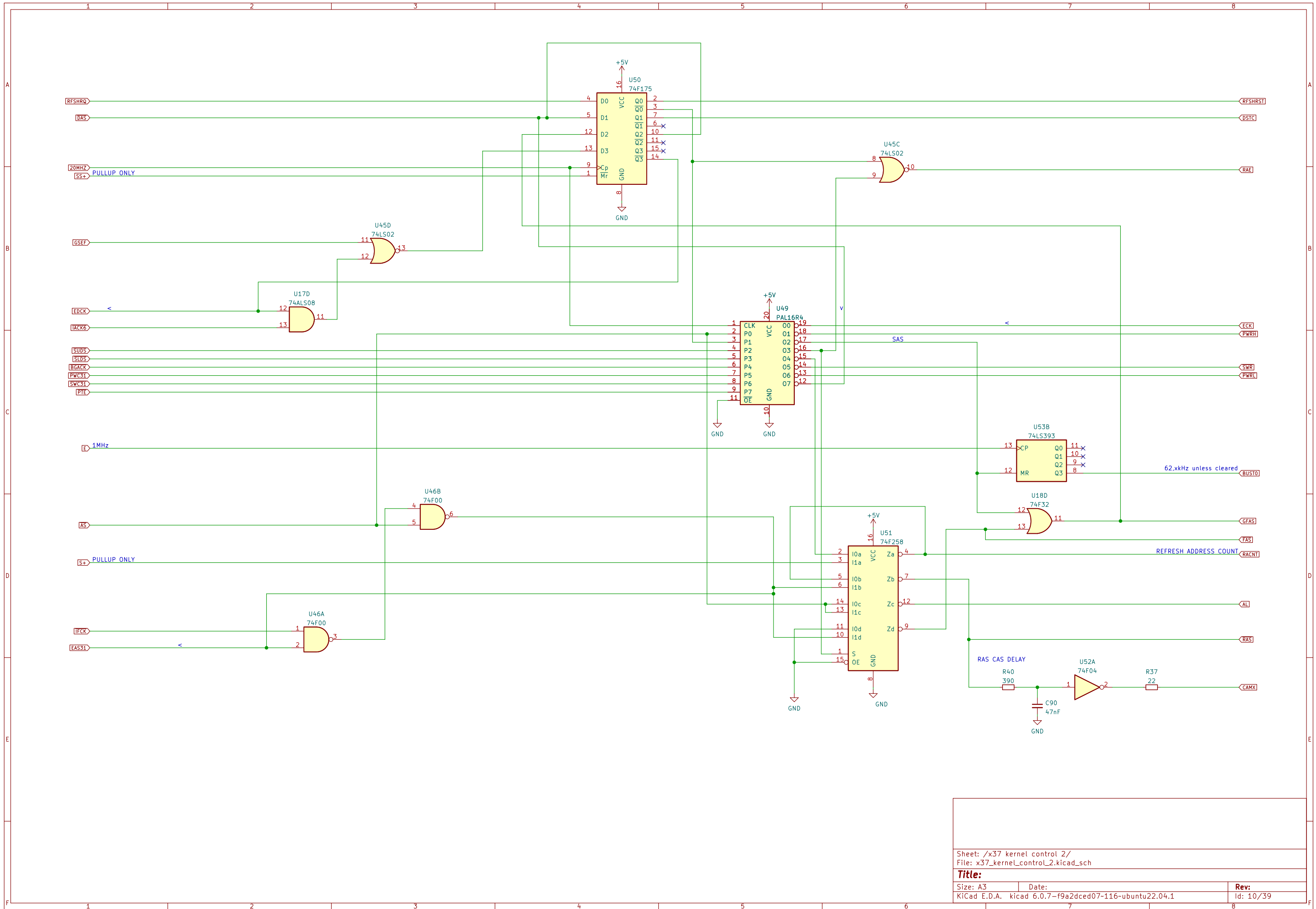

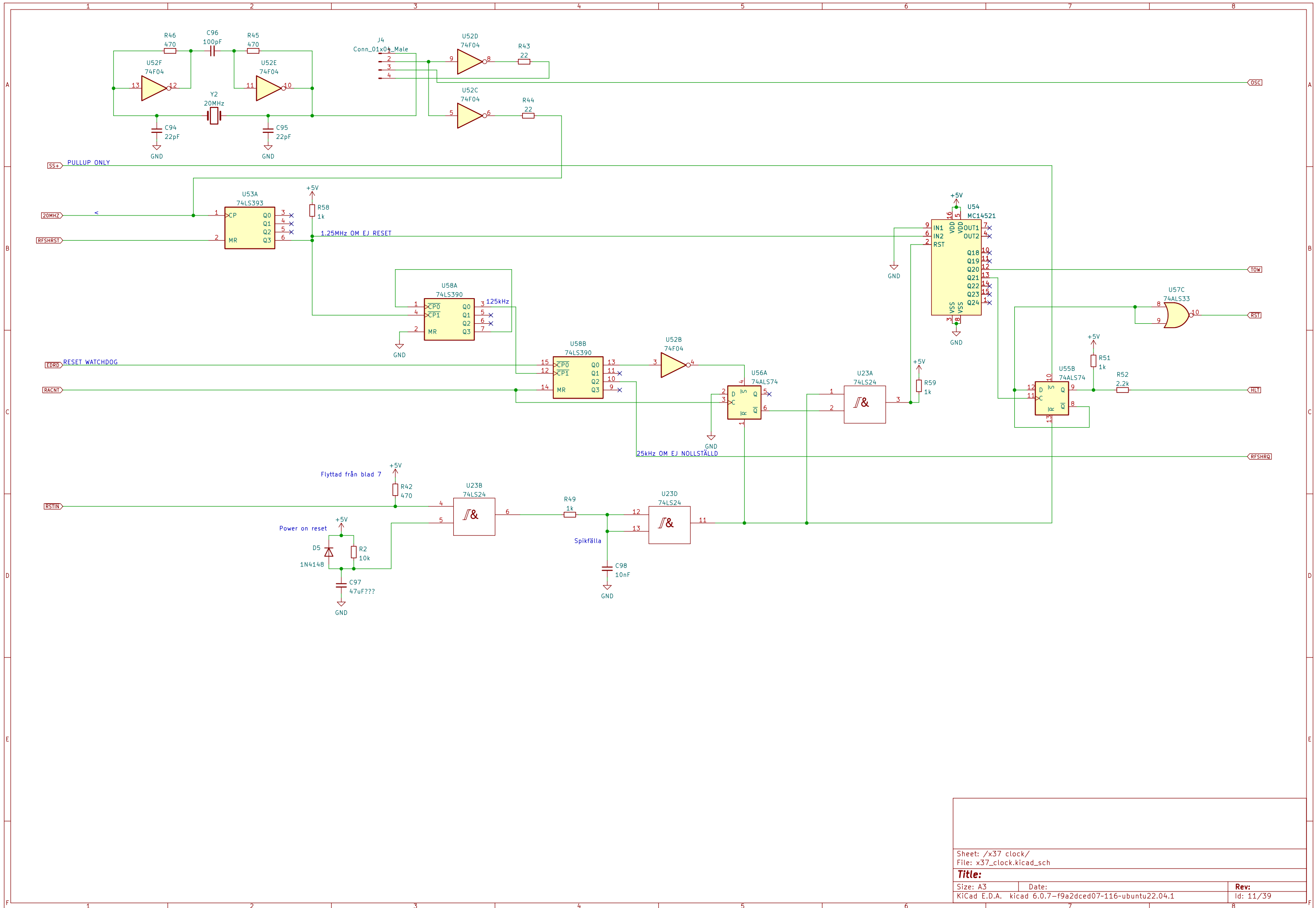

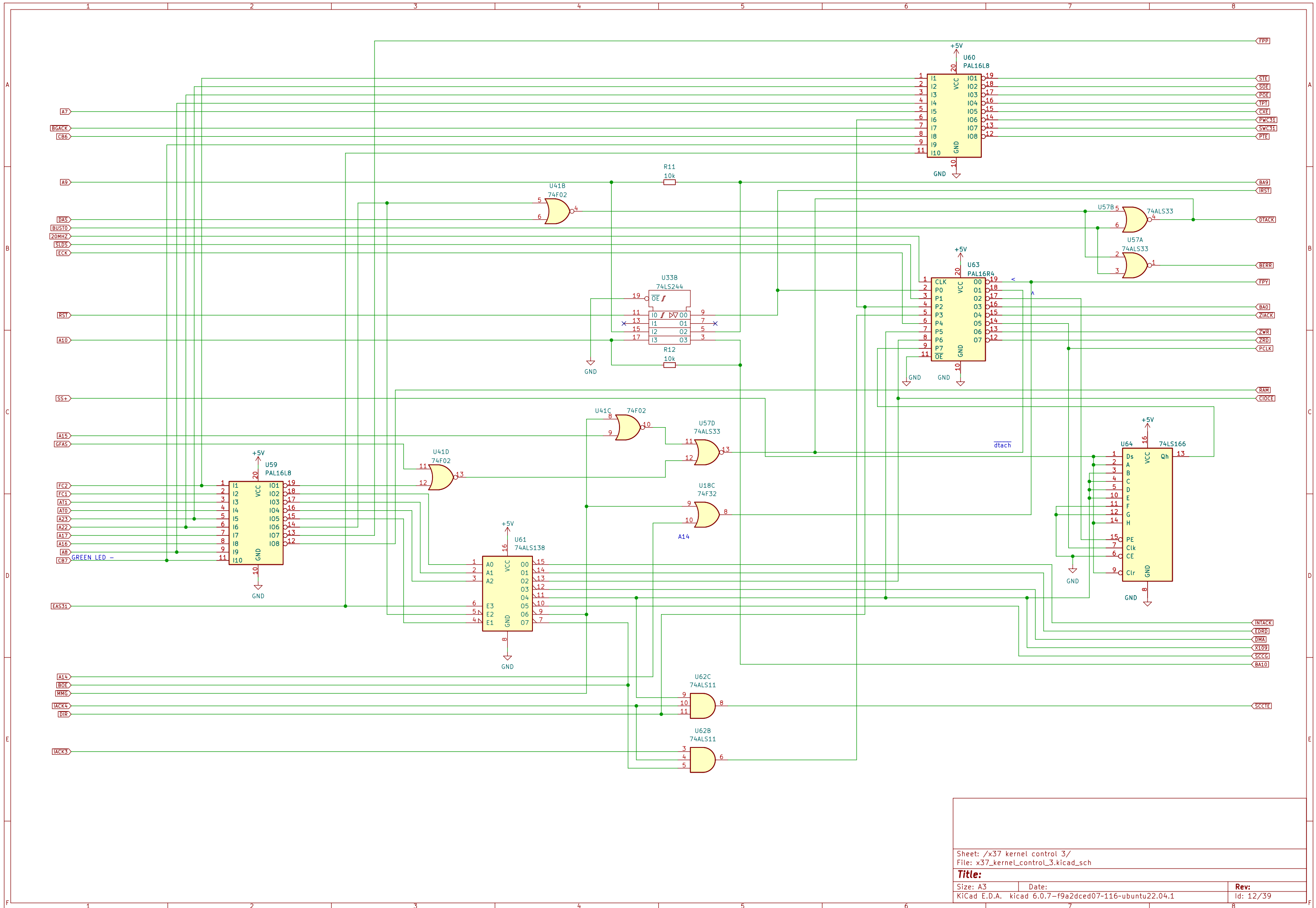

Sheet: /x37 kernel control 3/  
 File: x37\_kernel\_control\_3.kicad\_sch

**Title:**

Size: A3	Date:	Rev:
KiCad E.D.A. kicad 6.0.7-f9a2dced07-116-ubuntu22.04.1		Id: 12/39

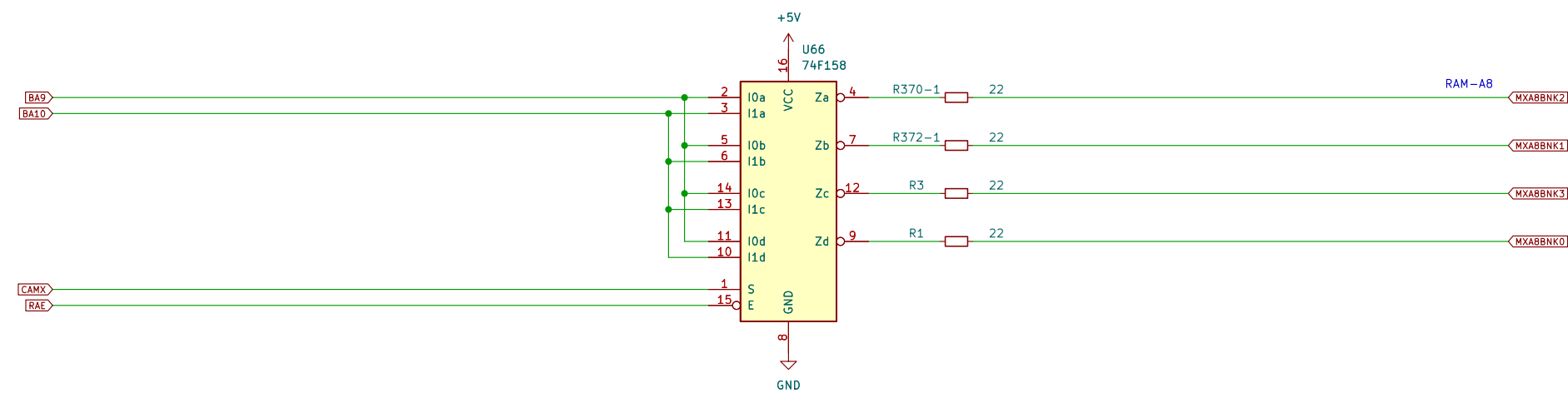
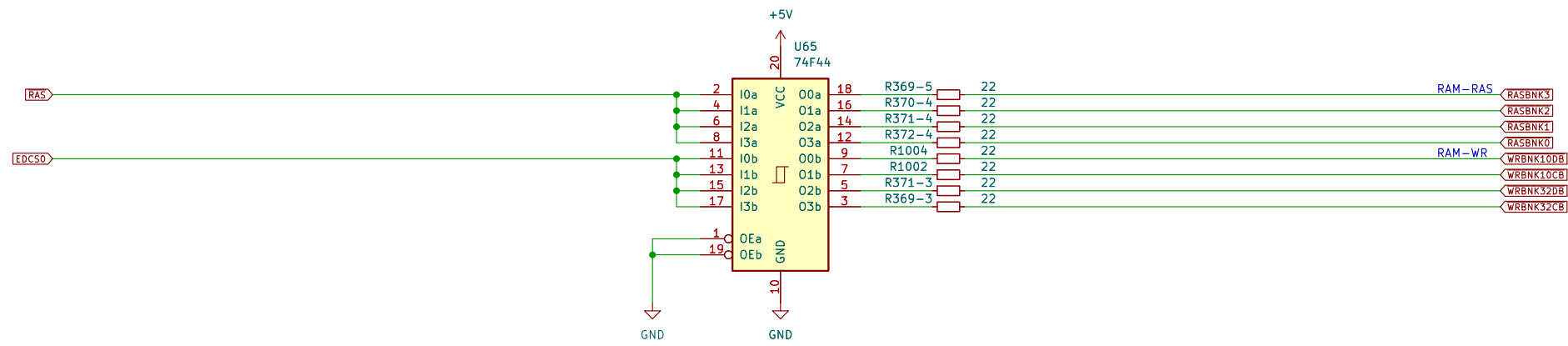

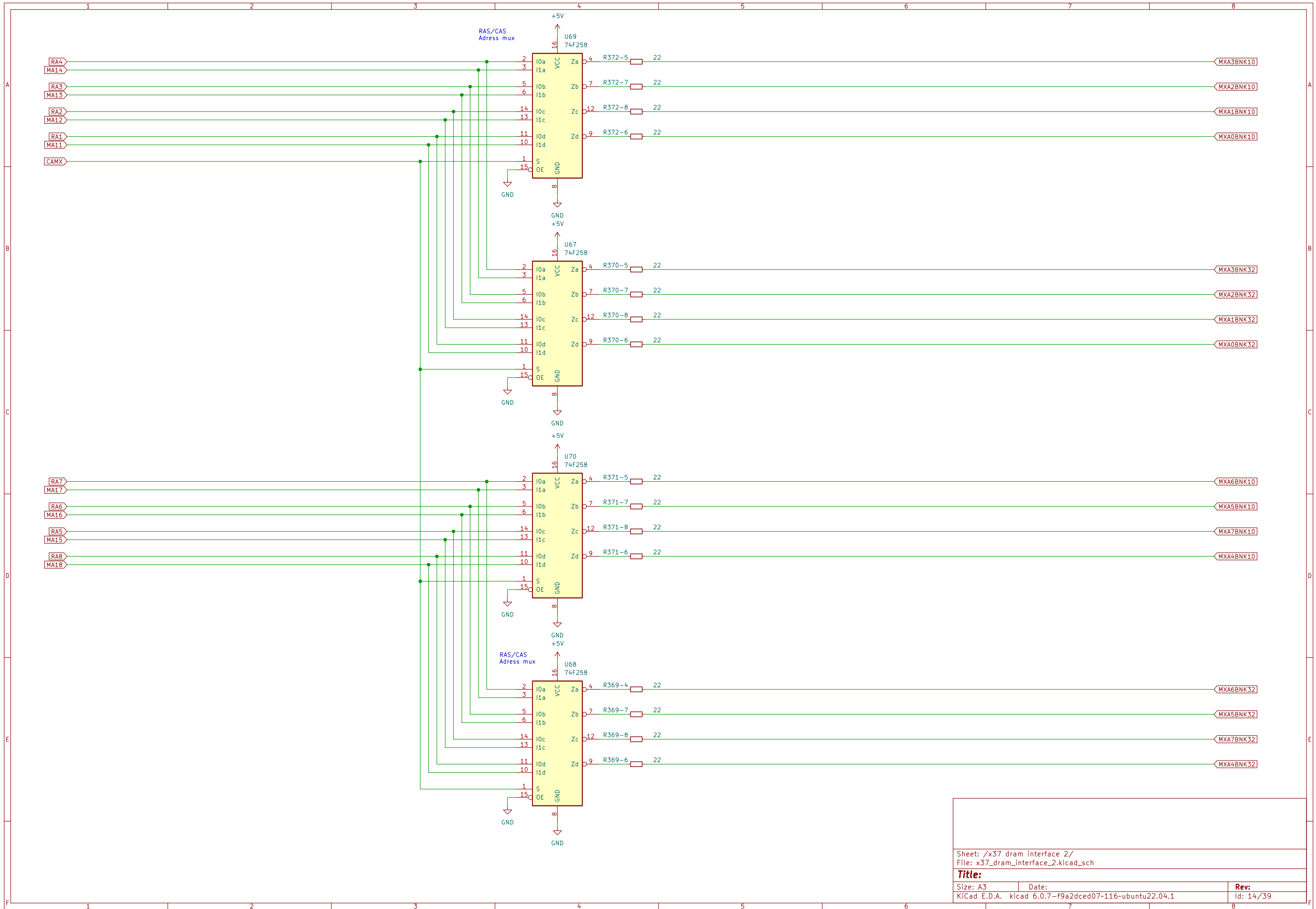

Sheet: /x37 dram interface 2/		
File: x37_dram_interface_2.kicad_sch		
<b>Title:</b>		
Size: A3	Date:	Rev:
KiCad E.D.A. kicad 6.0.7-f9a2dced07-116-ubuntu22.04.1		Id: 14/39

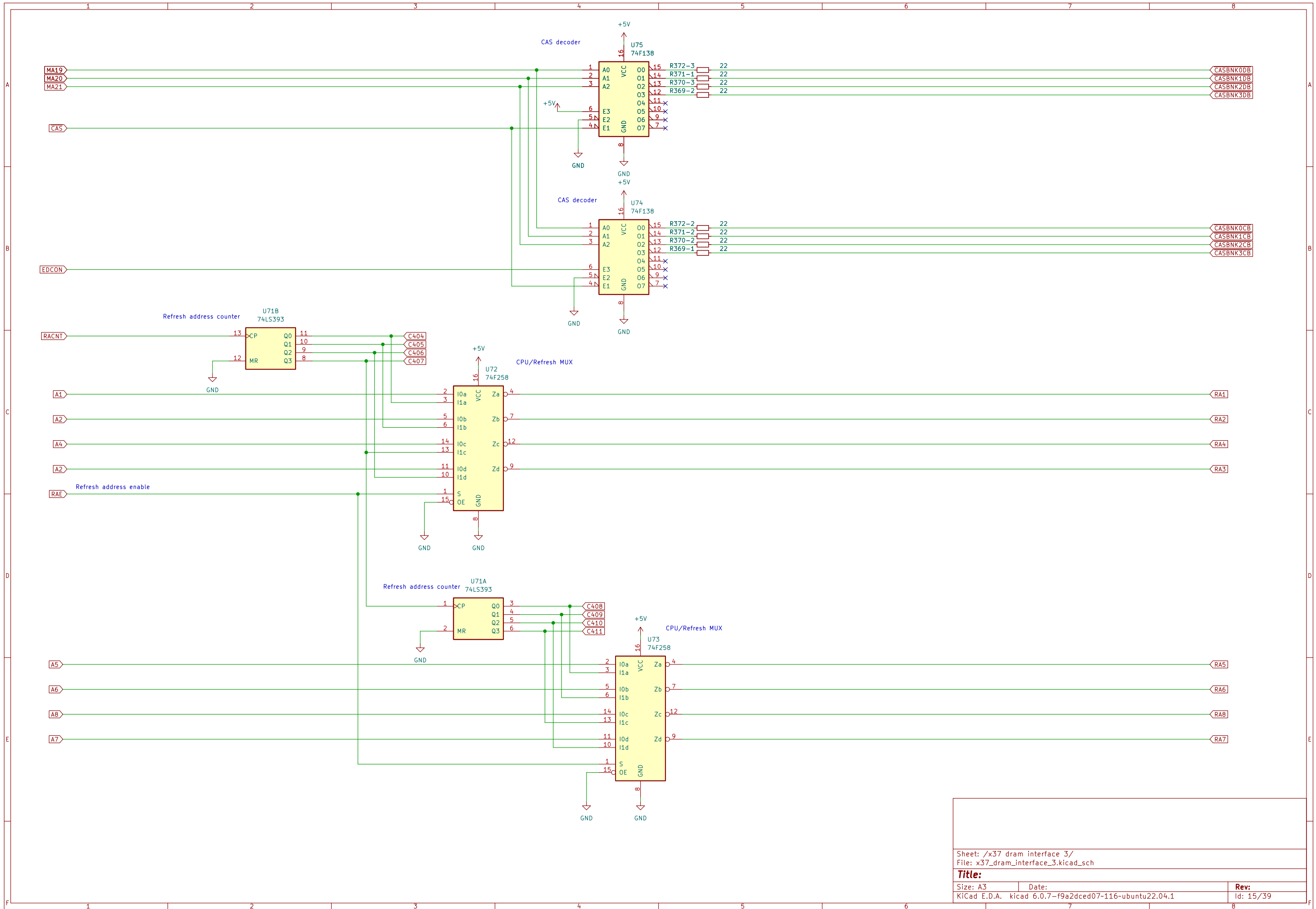

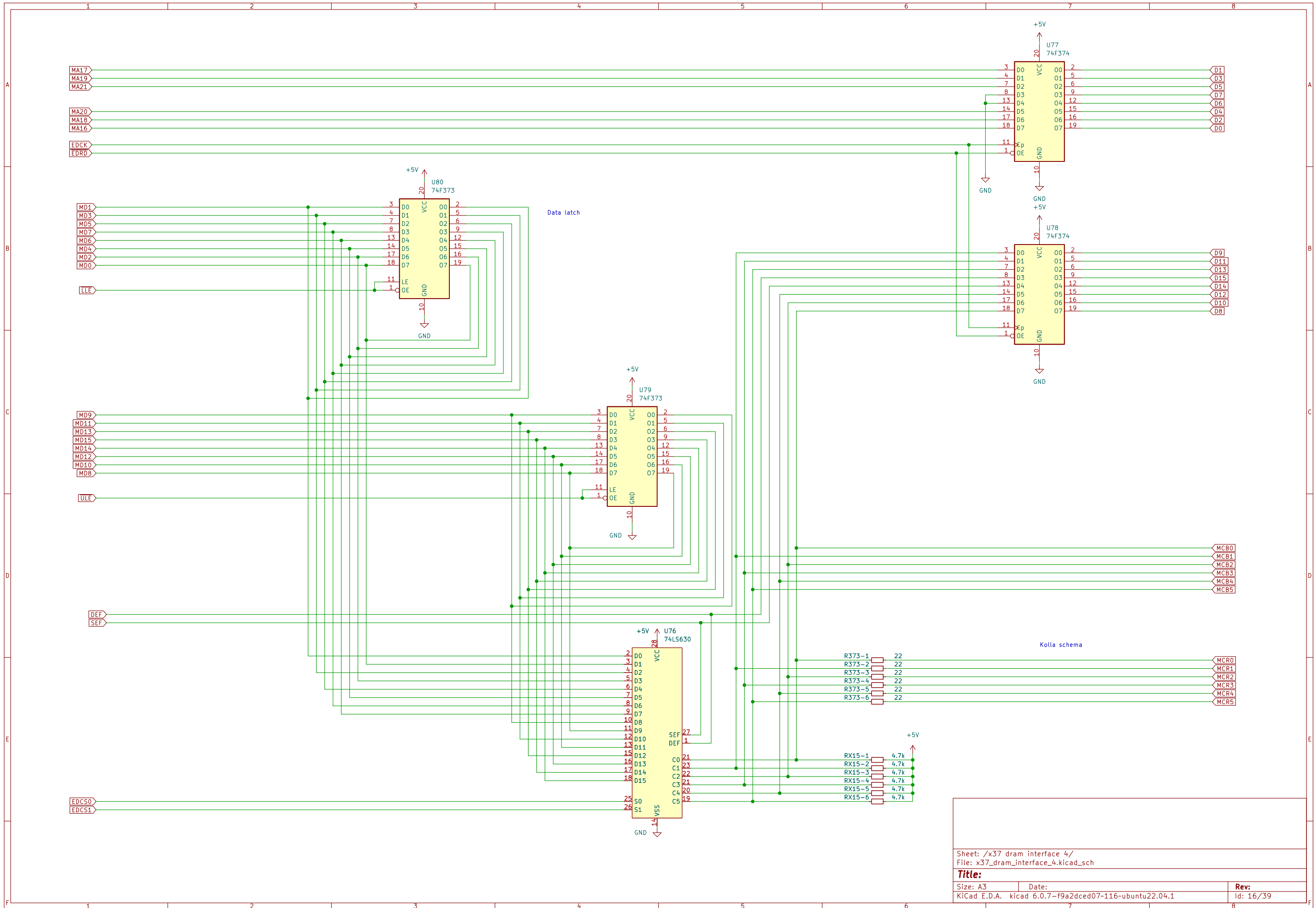



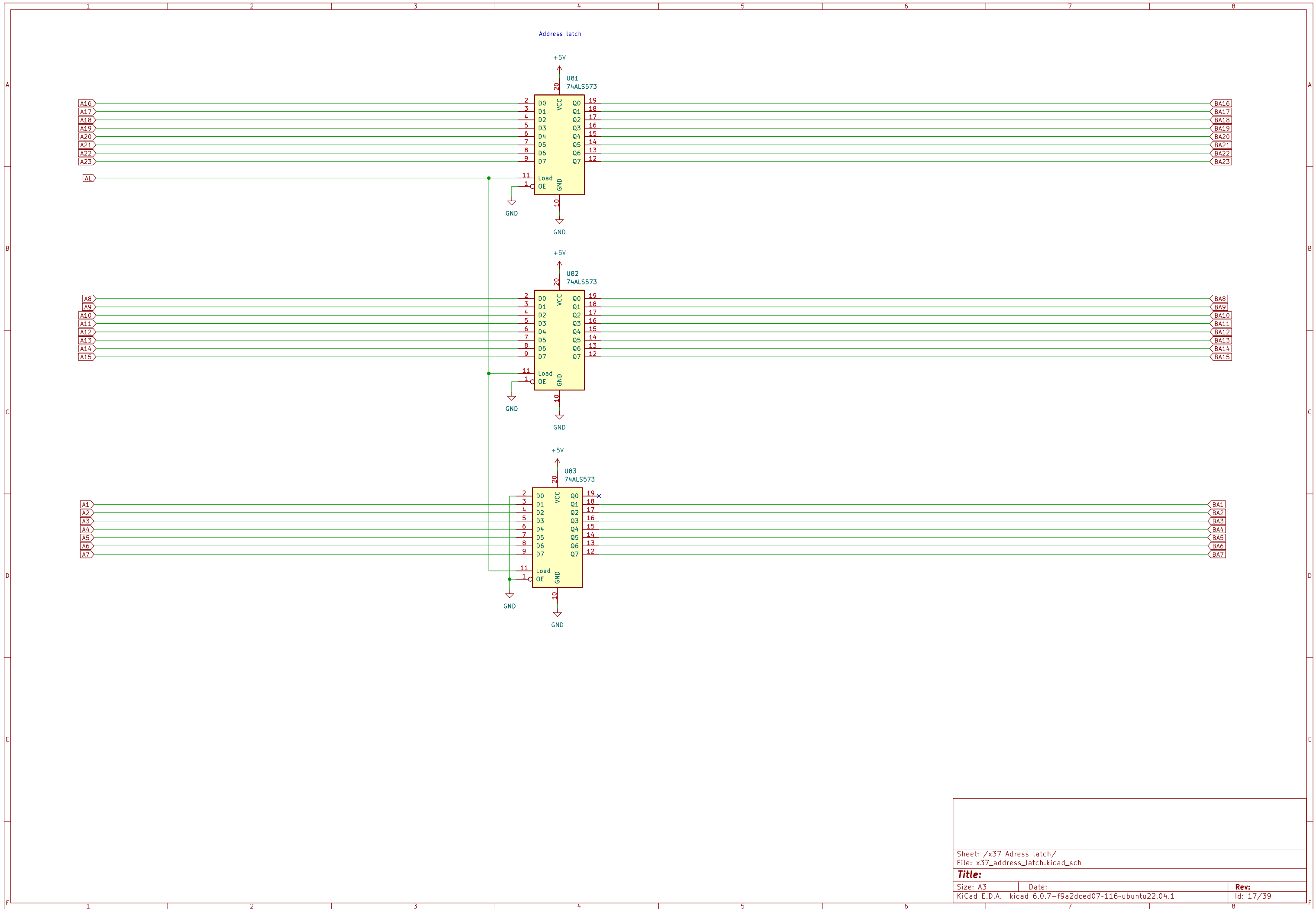

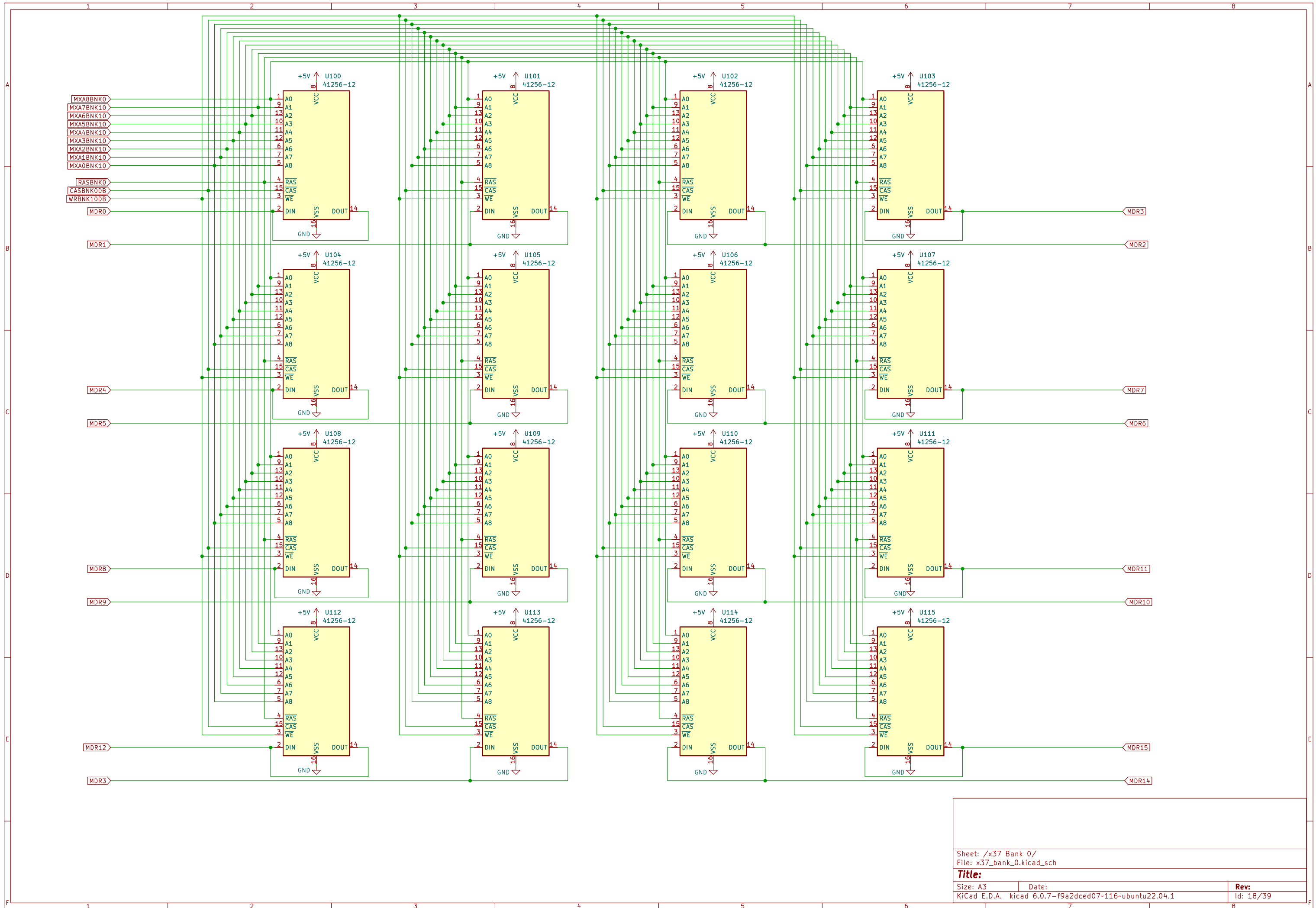

Sheet: /x37 Bank 0/  
File: x37\_bank\_0.kicad\_sch  
**Title:**  
Size: A3 Date:  
KiCad E.D.A. kicad 6.0.7-f9a2dced07-116-ubuntu22.04.1 **Rev:**  
Id: 18/39

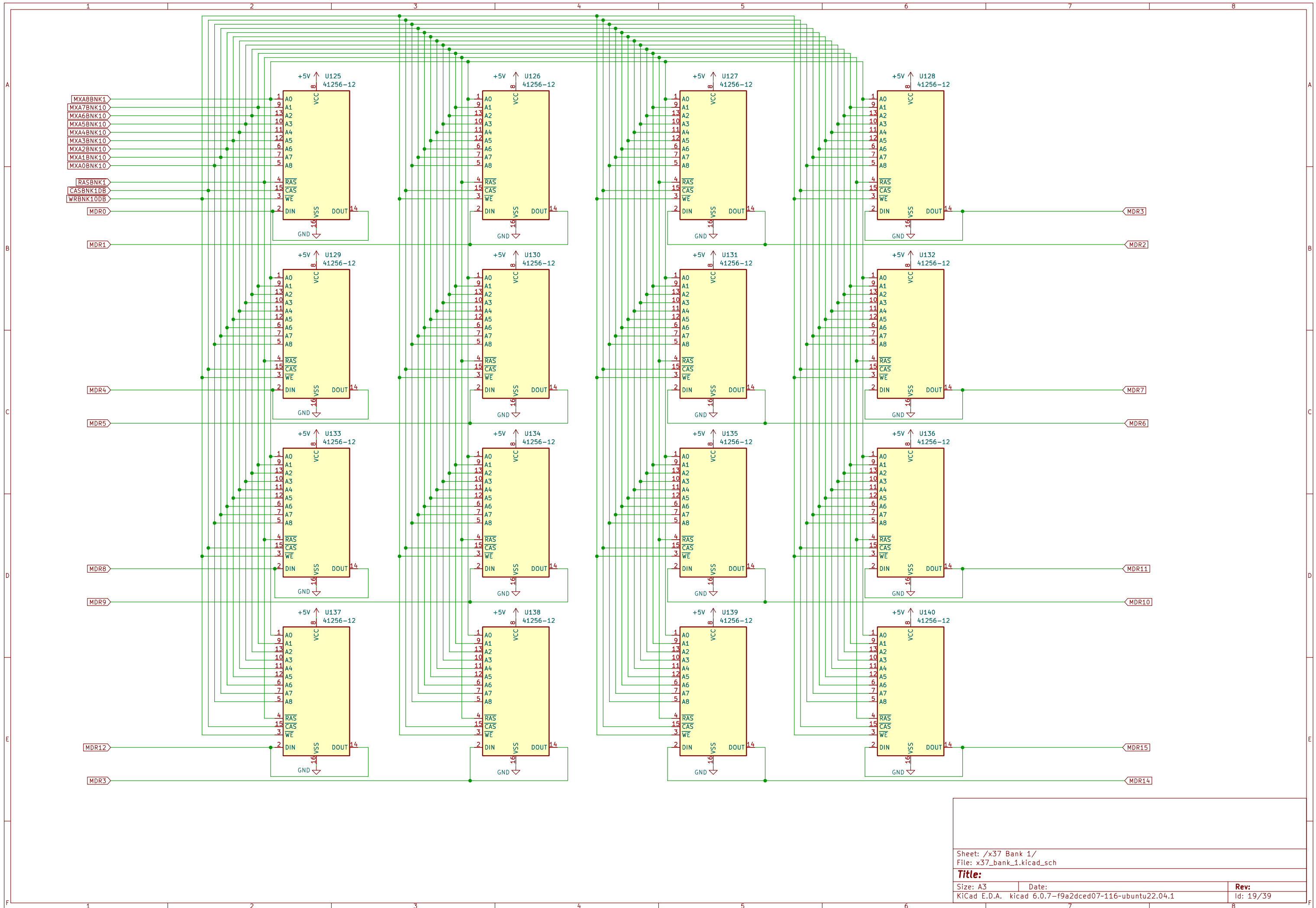

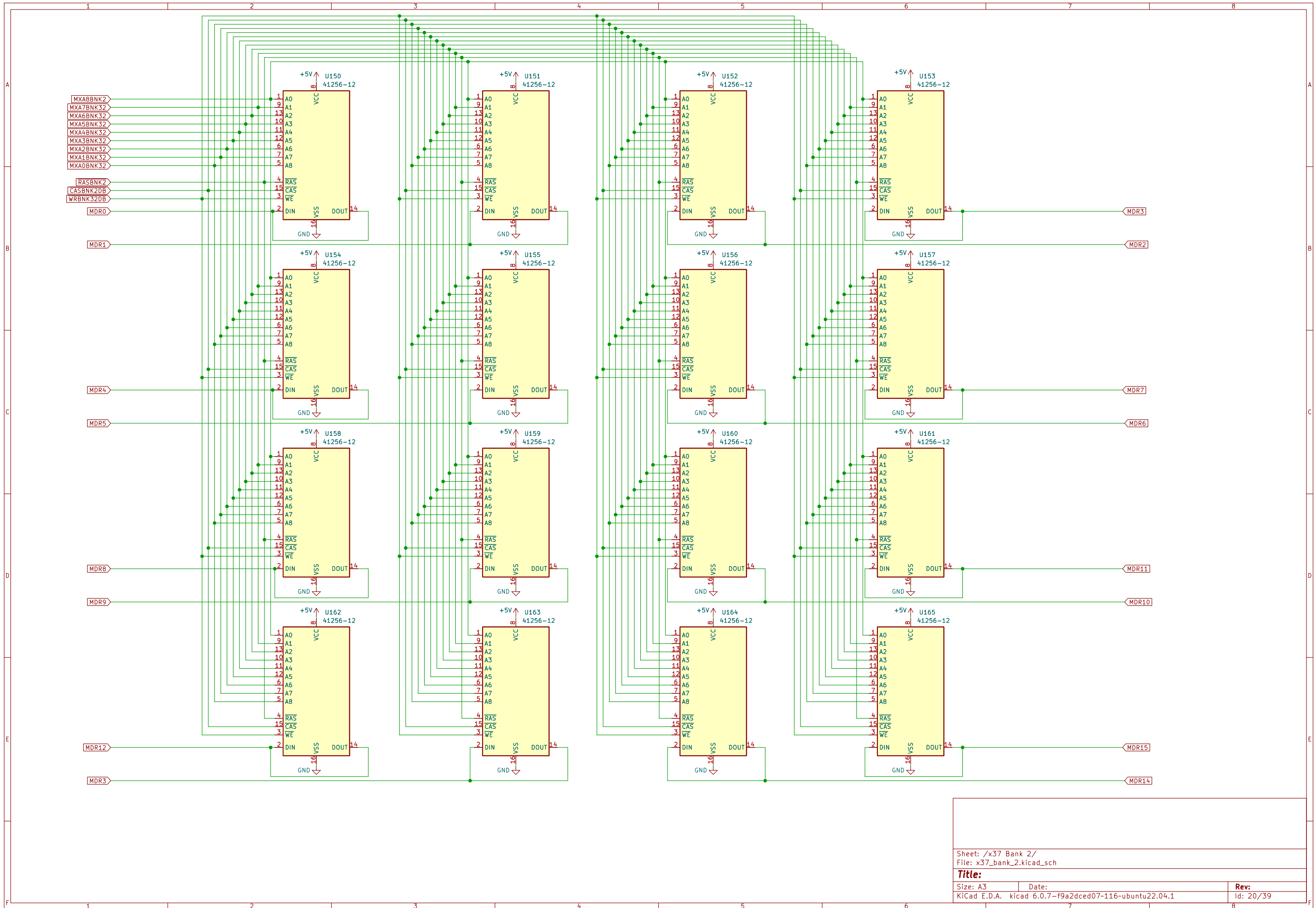

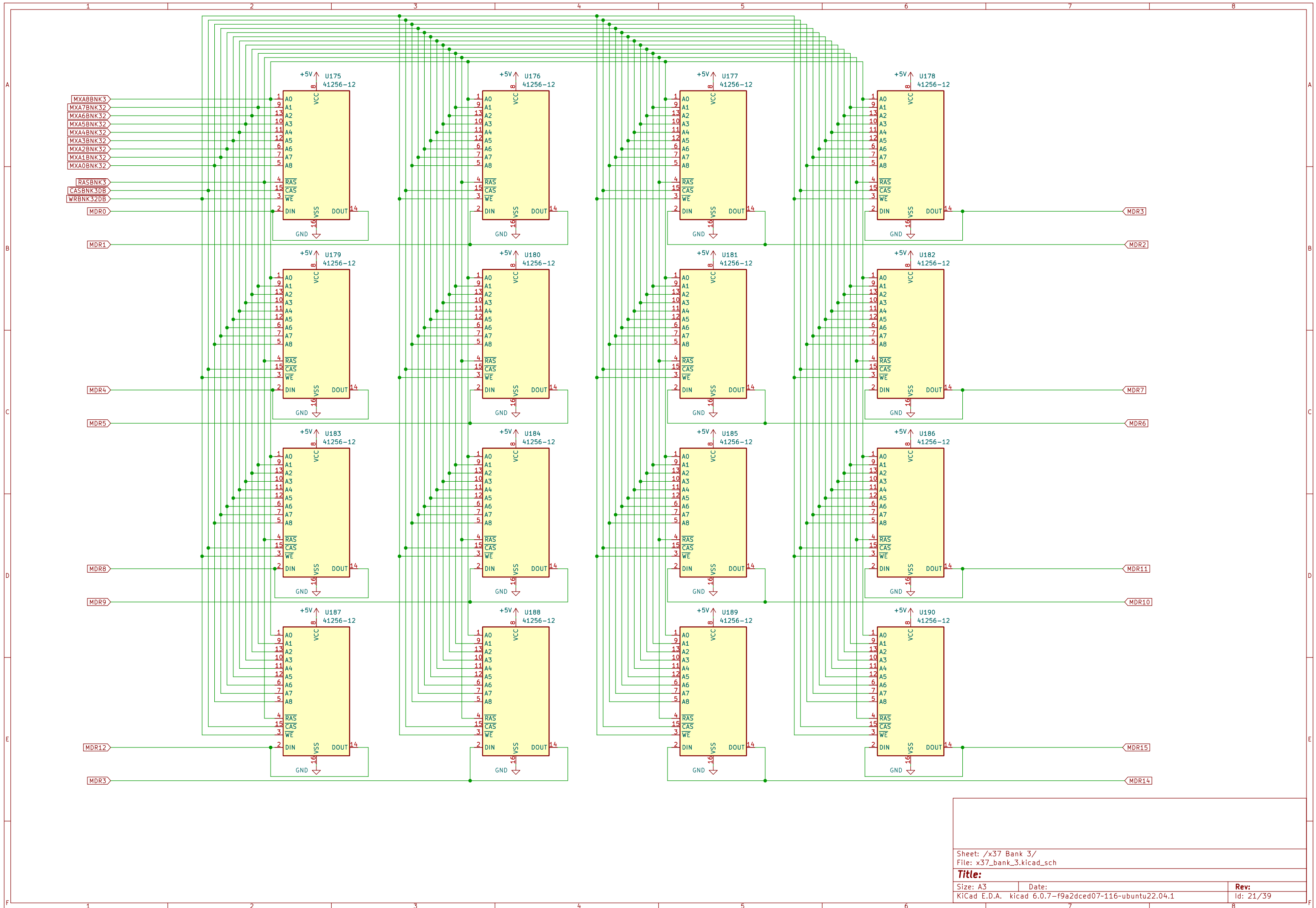

RASBNK1  
CASBNK1CB  
MXA8BNK0

MXA8BNK0  
MXA7BNK10  
MXA6BNK10  
MXA5BNK10  
MXA4BNK10  
MXA3BNK10  
MXA2BNK10  
MXA1BNK10  
MXA0BNK10

RASBNK0  
CASBNK0CB  
WRBNK10CB

MCR0

MCR2

MCR4

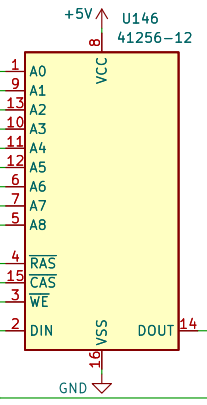
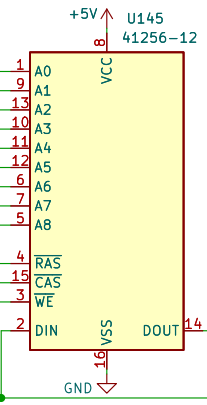
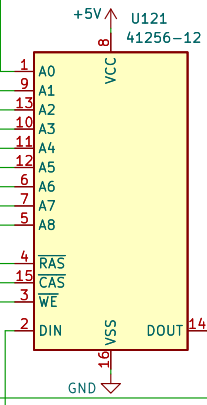
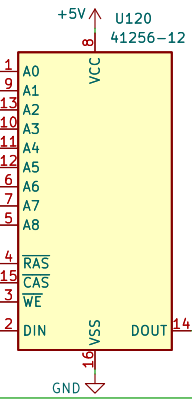
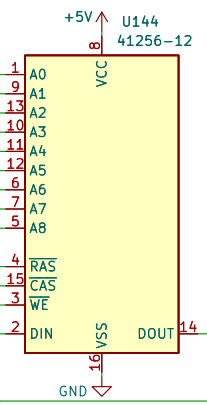
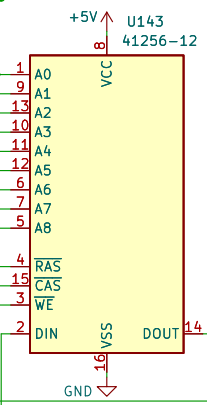
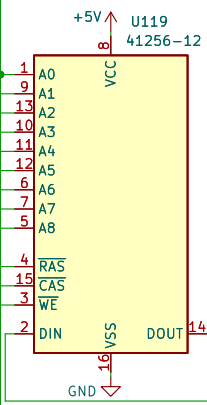
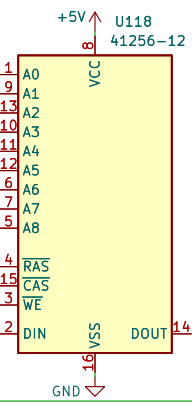
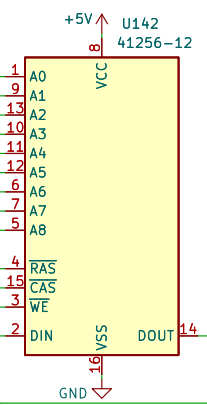
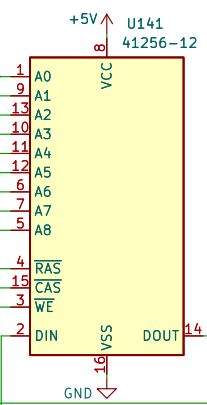
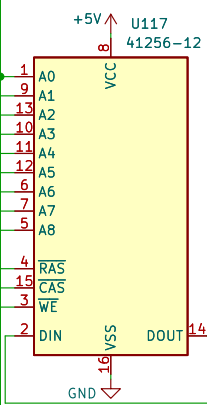
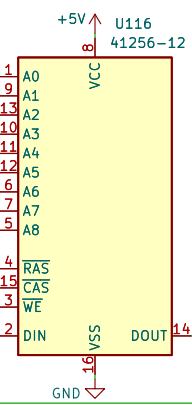

MCR1

MCR3

MCR5

Sheet: /x37 Coor Bank 0-1/ File: x37_coor_bank_0_1.kicad_sch		
<b>Title:</b>		
Size: A3	Date:	Rev:
KiCad E.D.A. kicad 6.0.7-f9a2dced07-116-ubuntu22.04.1		Id: 22/39

RASBNK3  
CASBNK3CB  
MXA8BNK3

MXA8BNK2  
MXA7BNK32  
MXA6BNK32  
MXA5BNK32  
MXA4BNK32  
MXA3BNK32  
MXA2BNK32  
MXA1BNK32  
MXA0BNK32

RASBNK2  
CASBNK2CB  
WRBNK32CB

MCR0

MCR2

MCR4

+5V U166  
41256-12

+5V U167  
41256-12

+5V U191  
41256-12

+5V U192  
41256-12

+5V U168  
41256-12

+5V U169  
41256-12

+5V U193  
41256-12

+5V U194  
41256-12

+5V U170  
41256-12

+5V U171  
41256-12

+5V U195  
41256-12

+5V U196  
41256-12

MCR1

MCR3

MCR5

Sheet: /x37 Coor Bank 2-3/ File: x37_coor_bank_2_3.kicad_sch		
<b>Title:</b>		
Size: A3	Date:	Rev:
KiCad E.D.A. kicad 6.0.7-f9a2dced07-116-ubuntu22.04.1		Id: 23/39

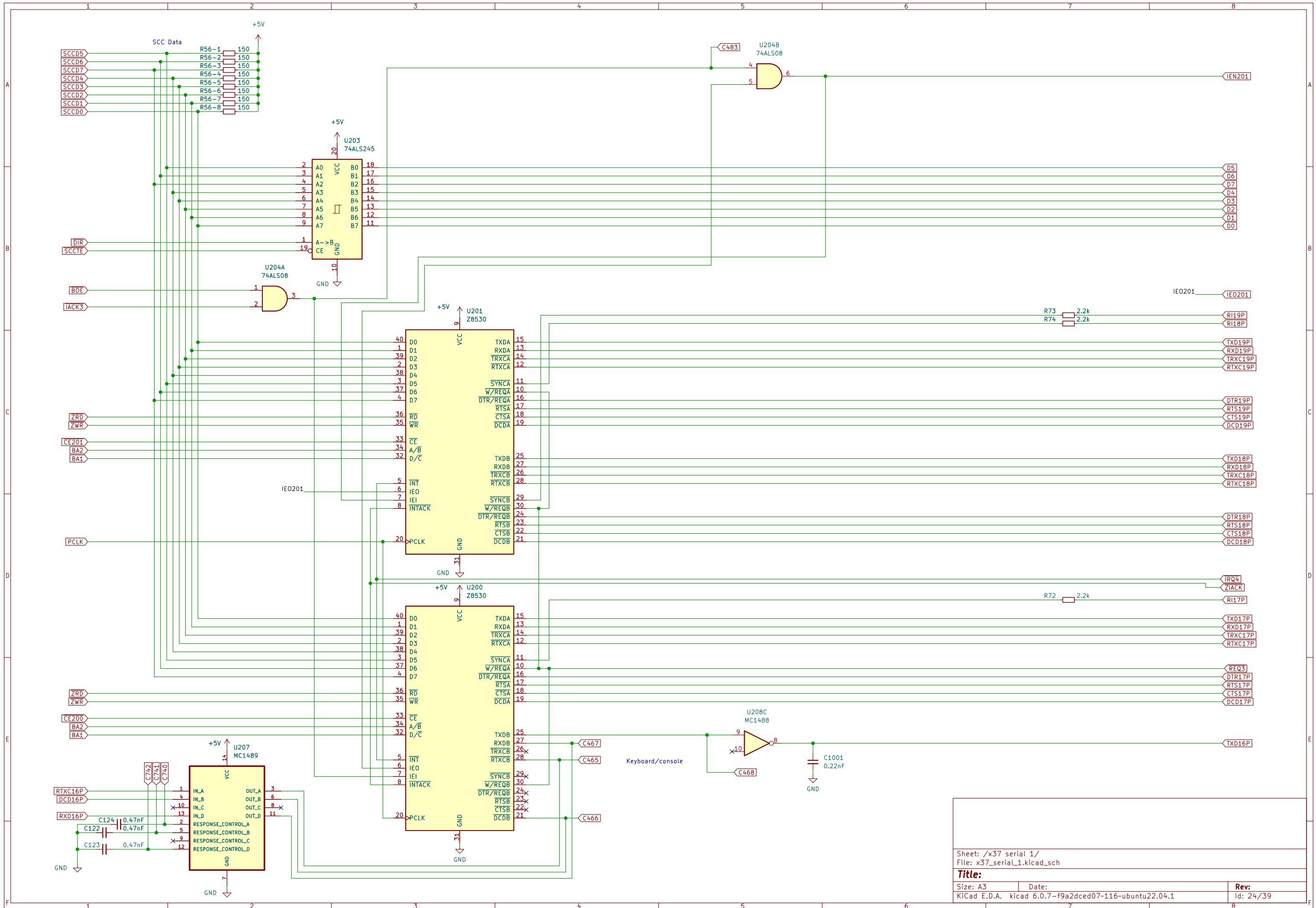



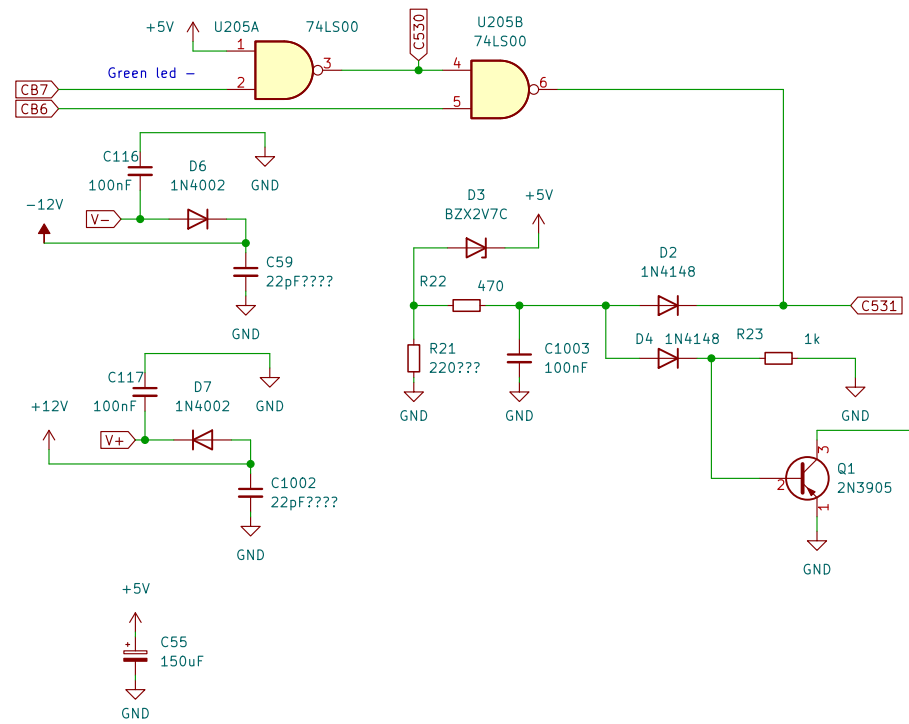
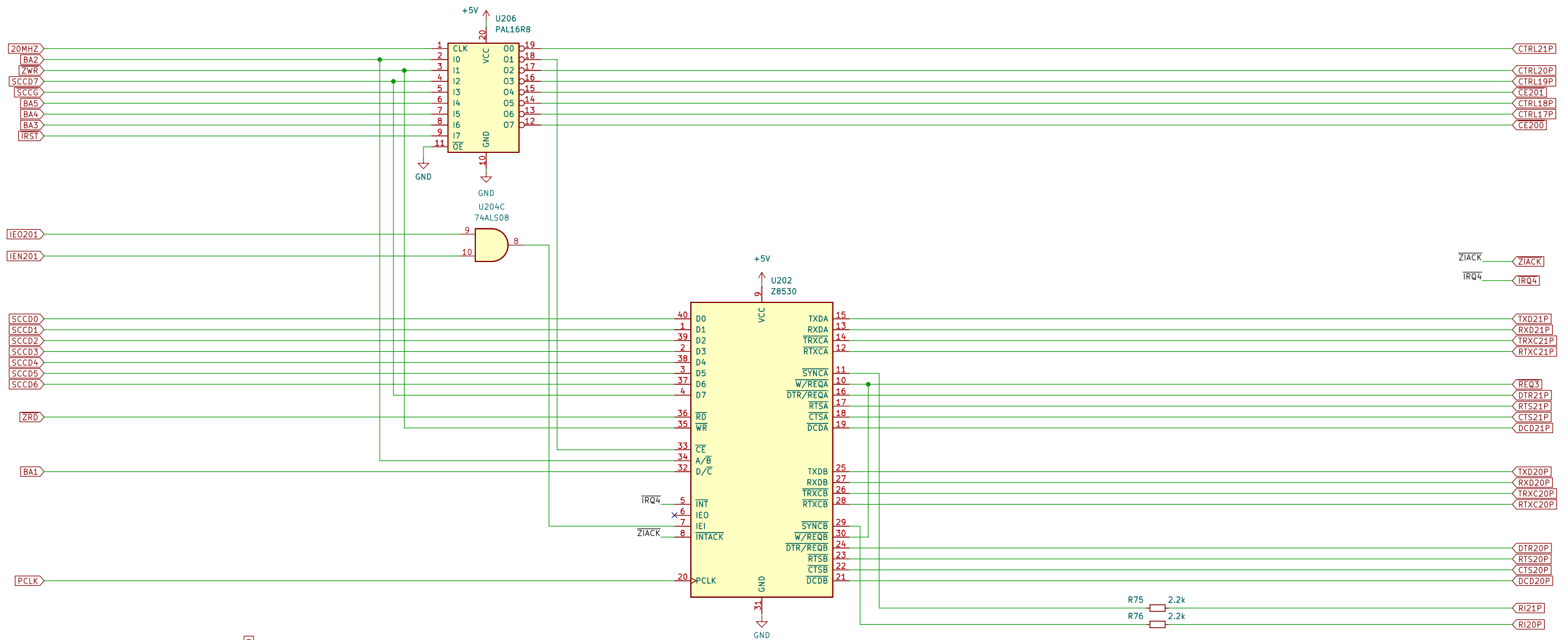

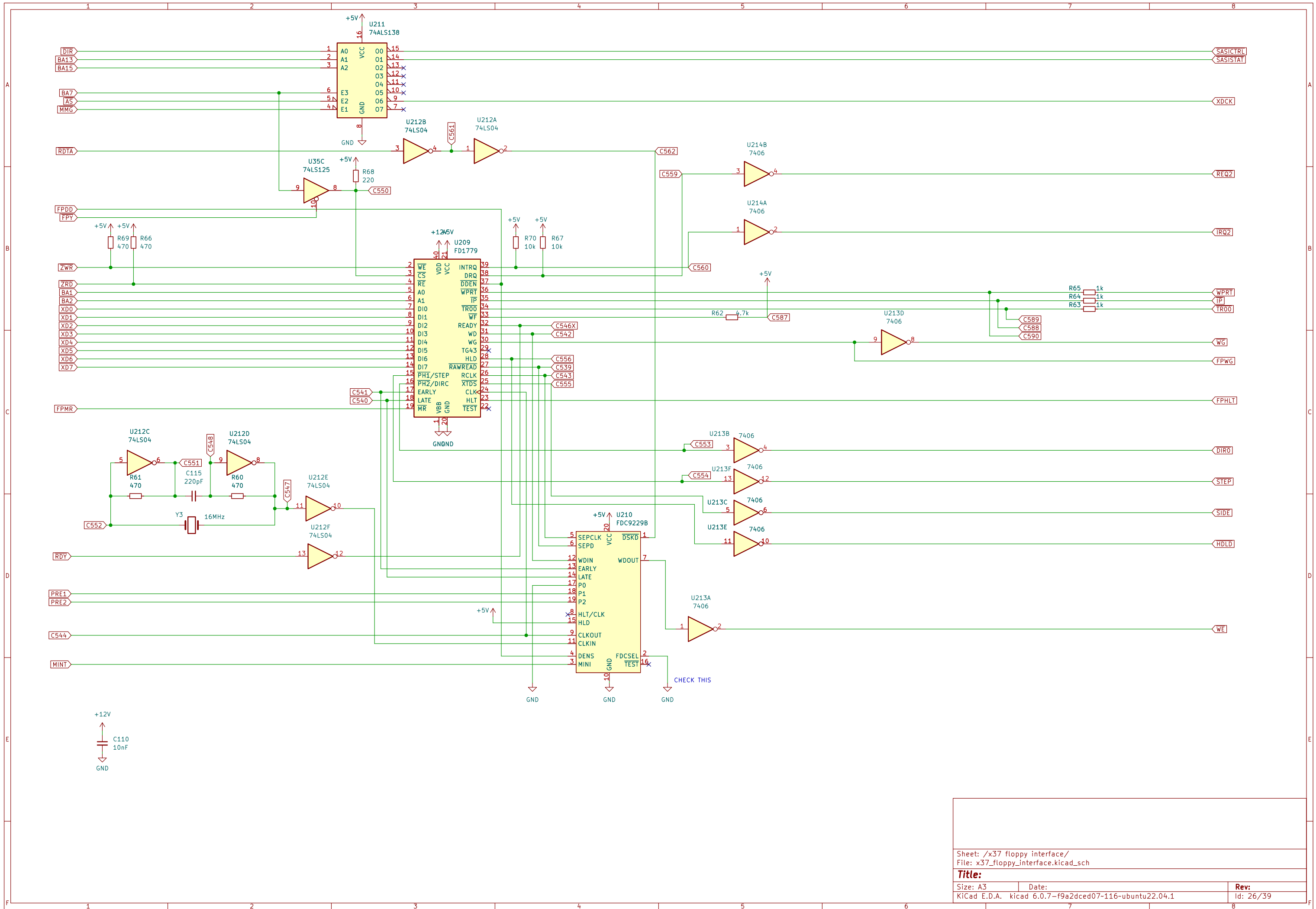

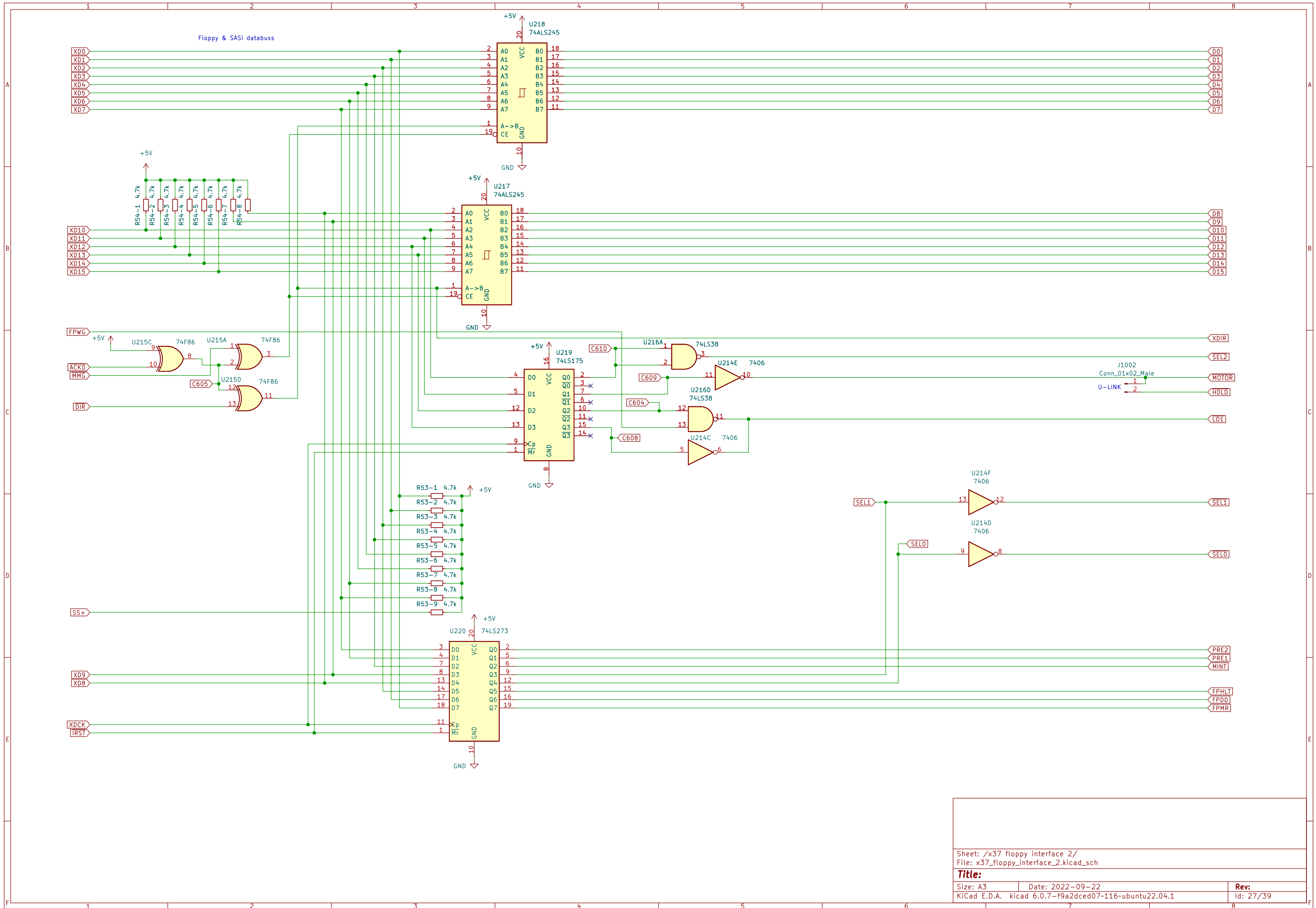

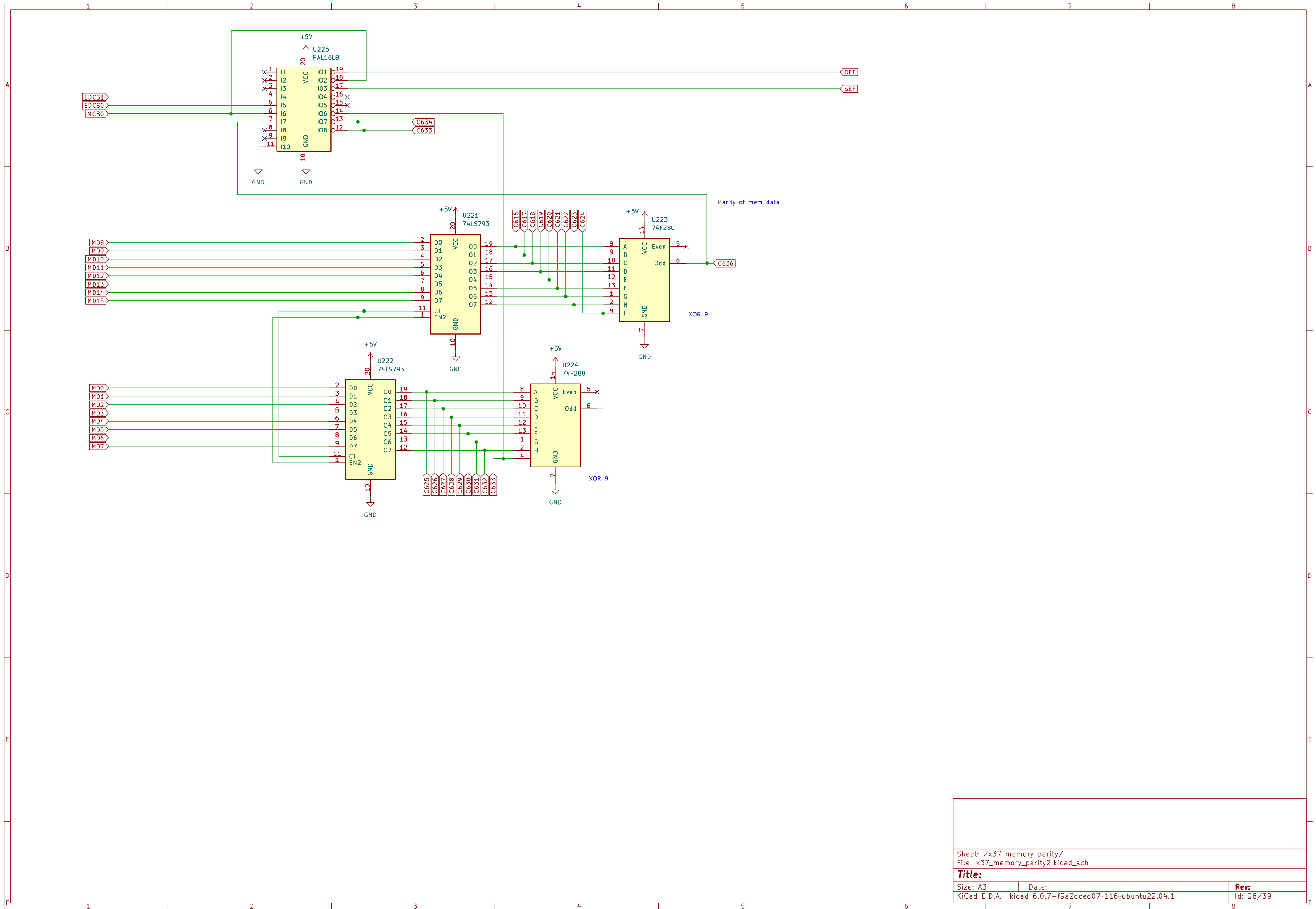

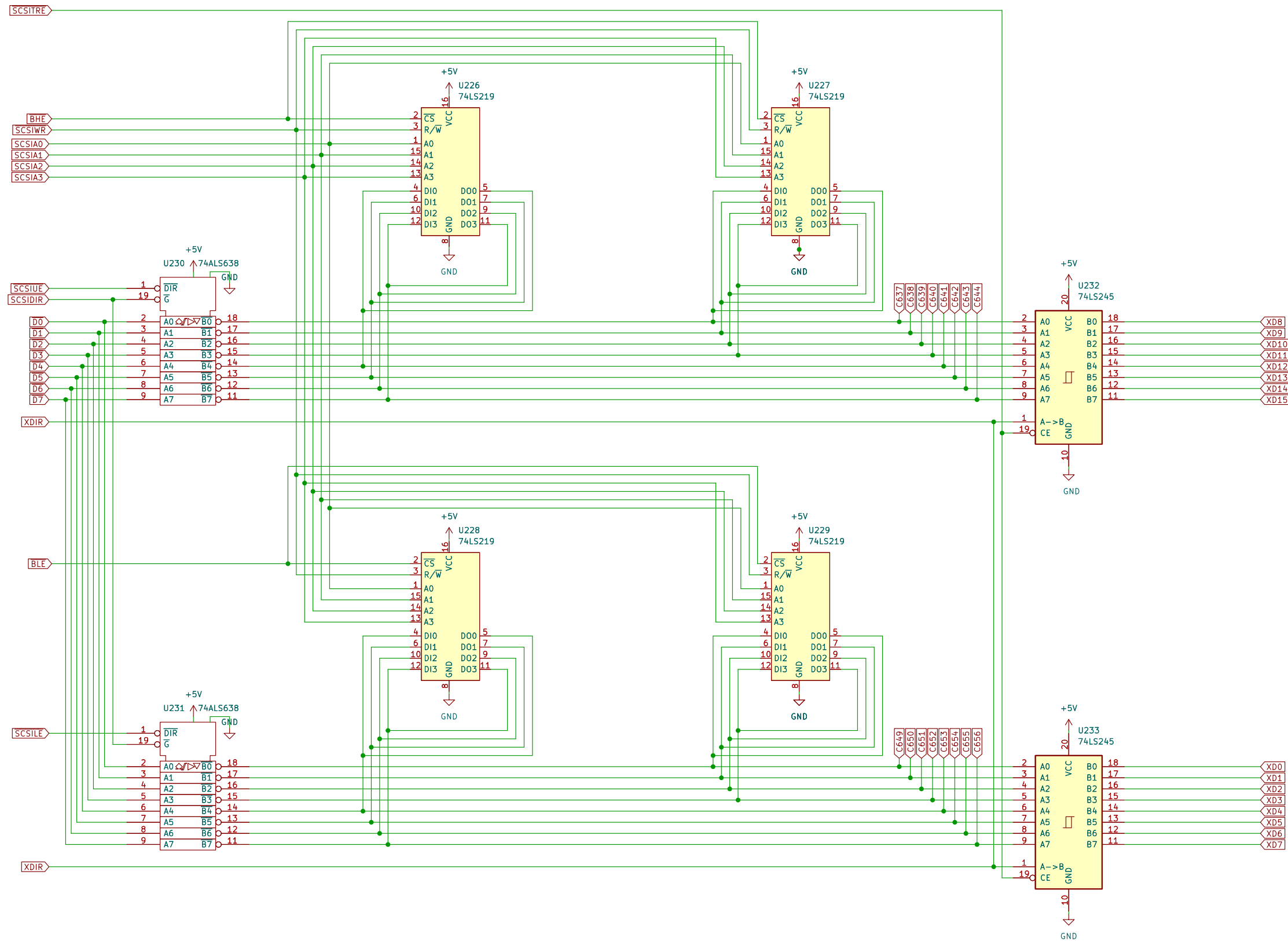

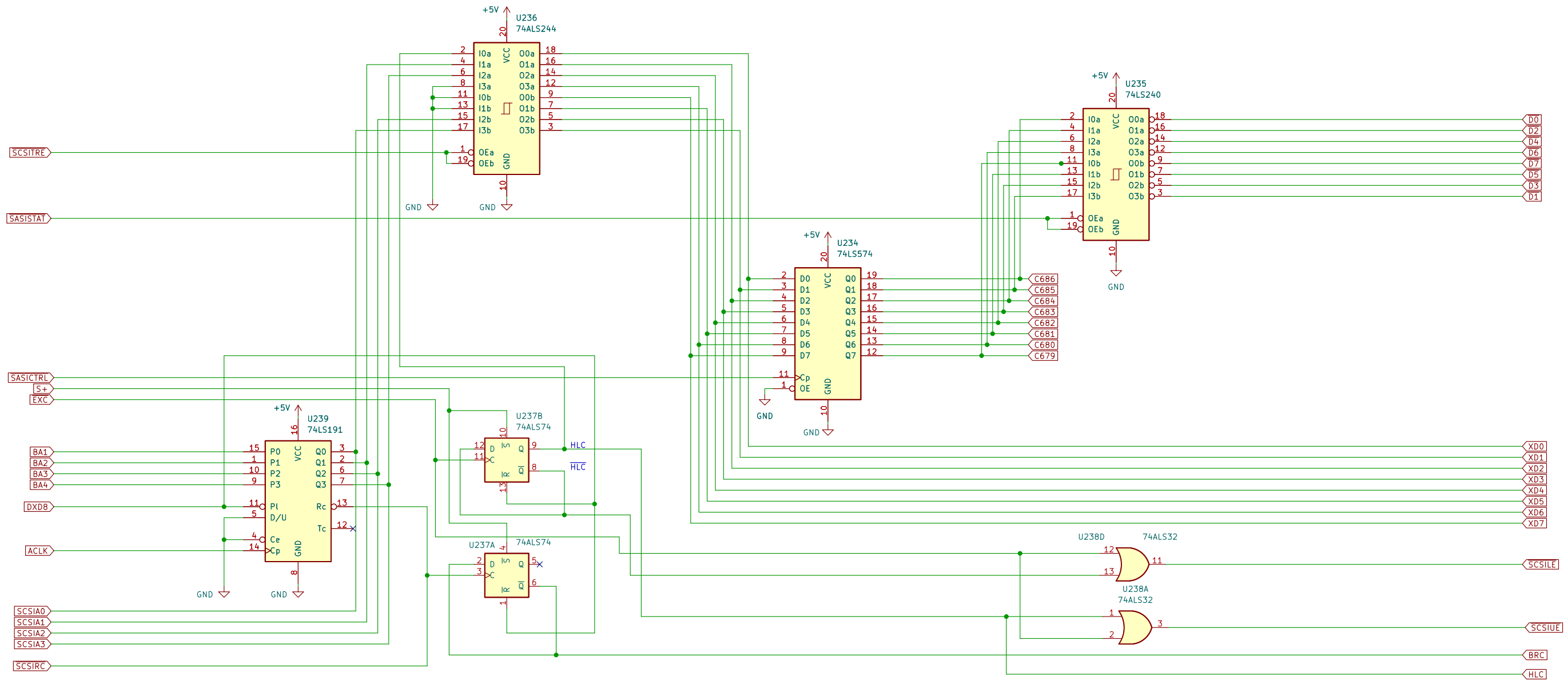

kar inte finnas nginstans på schemat

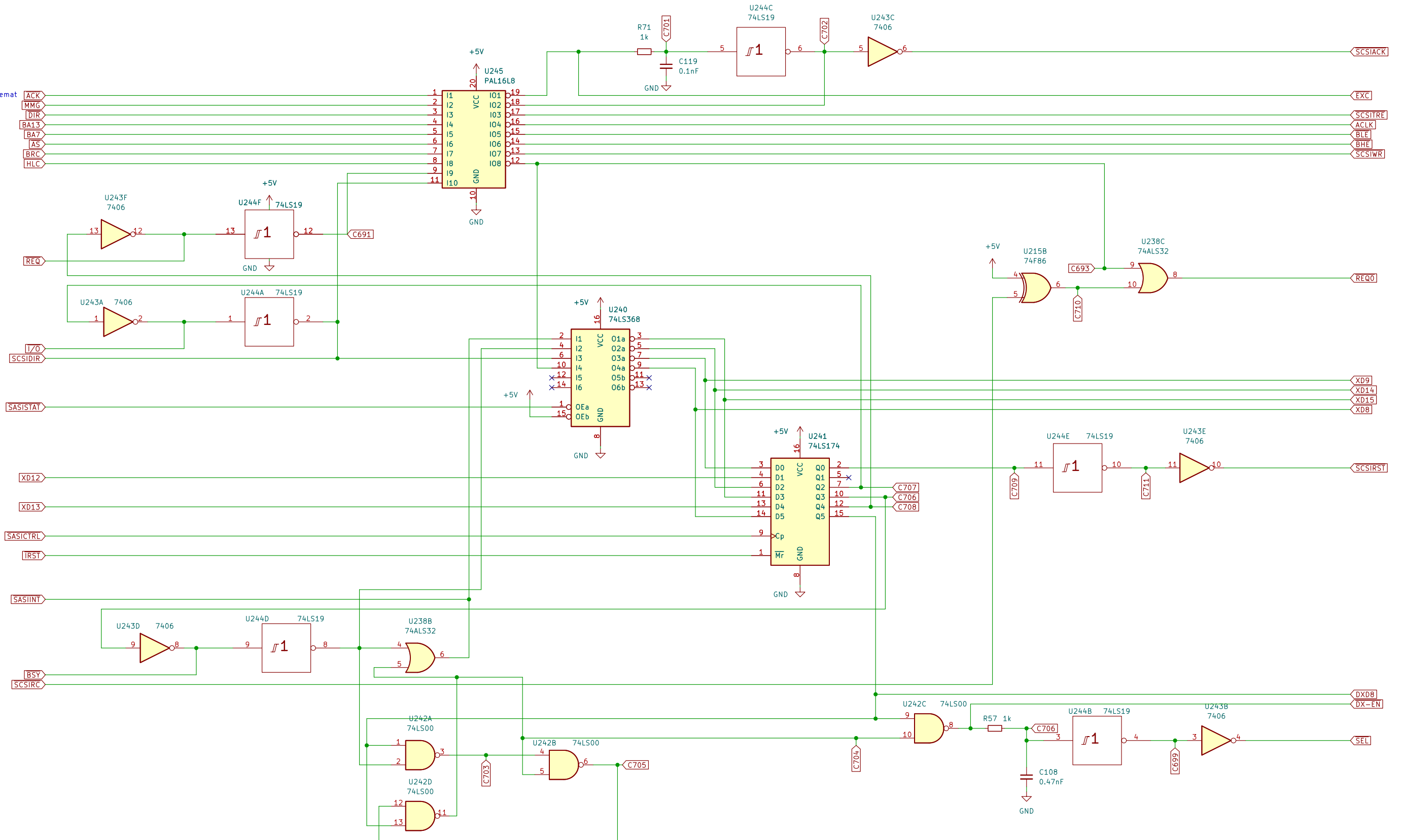

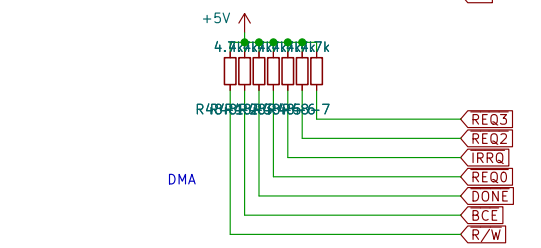
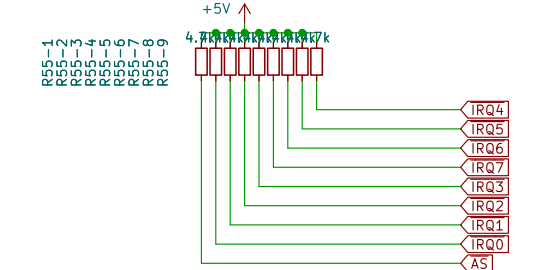
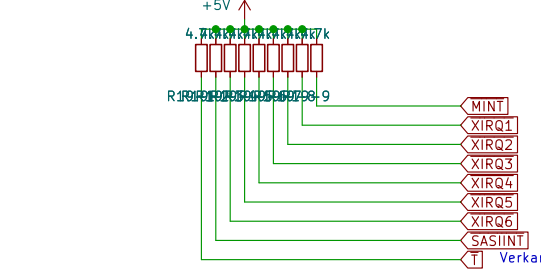
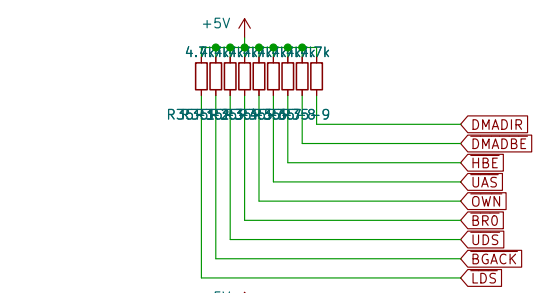
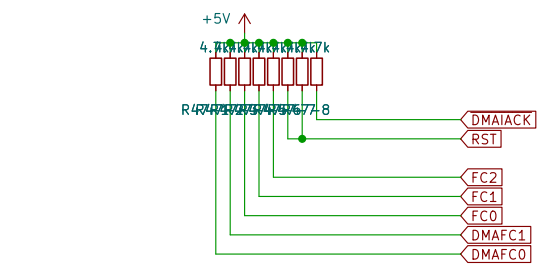
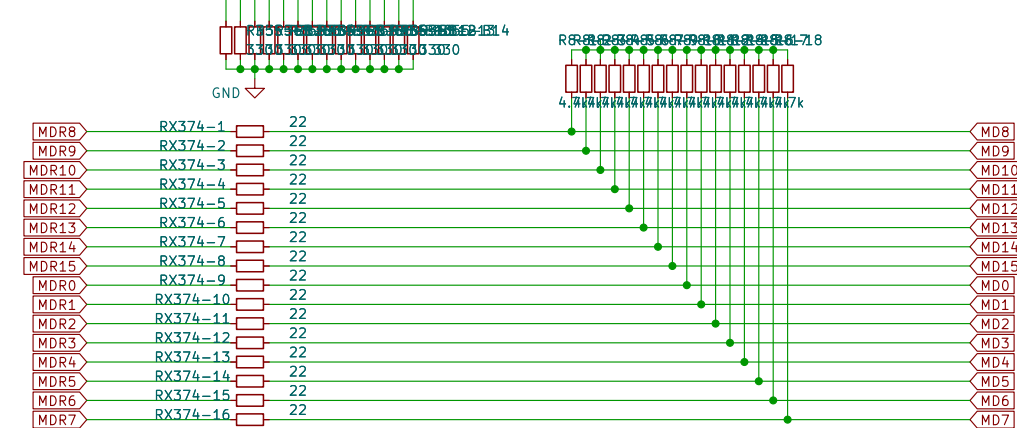
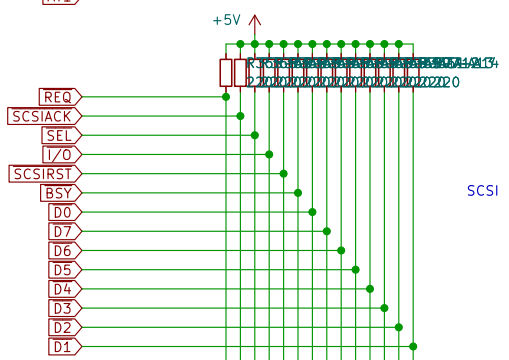
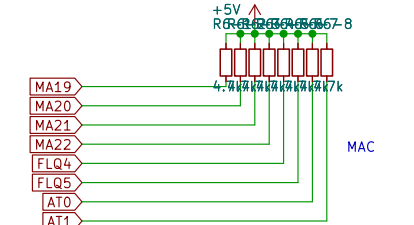
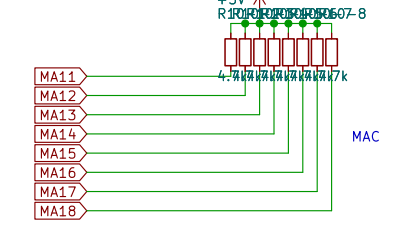
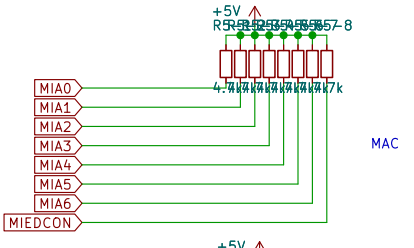
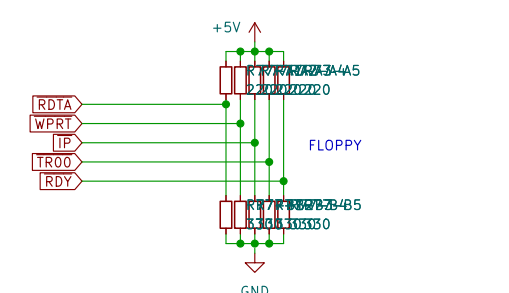



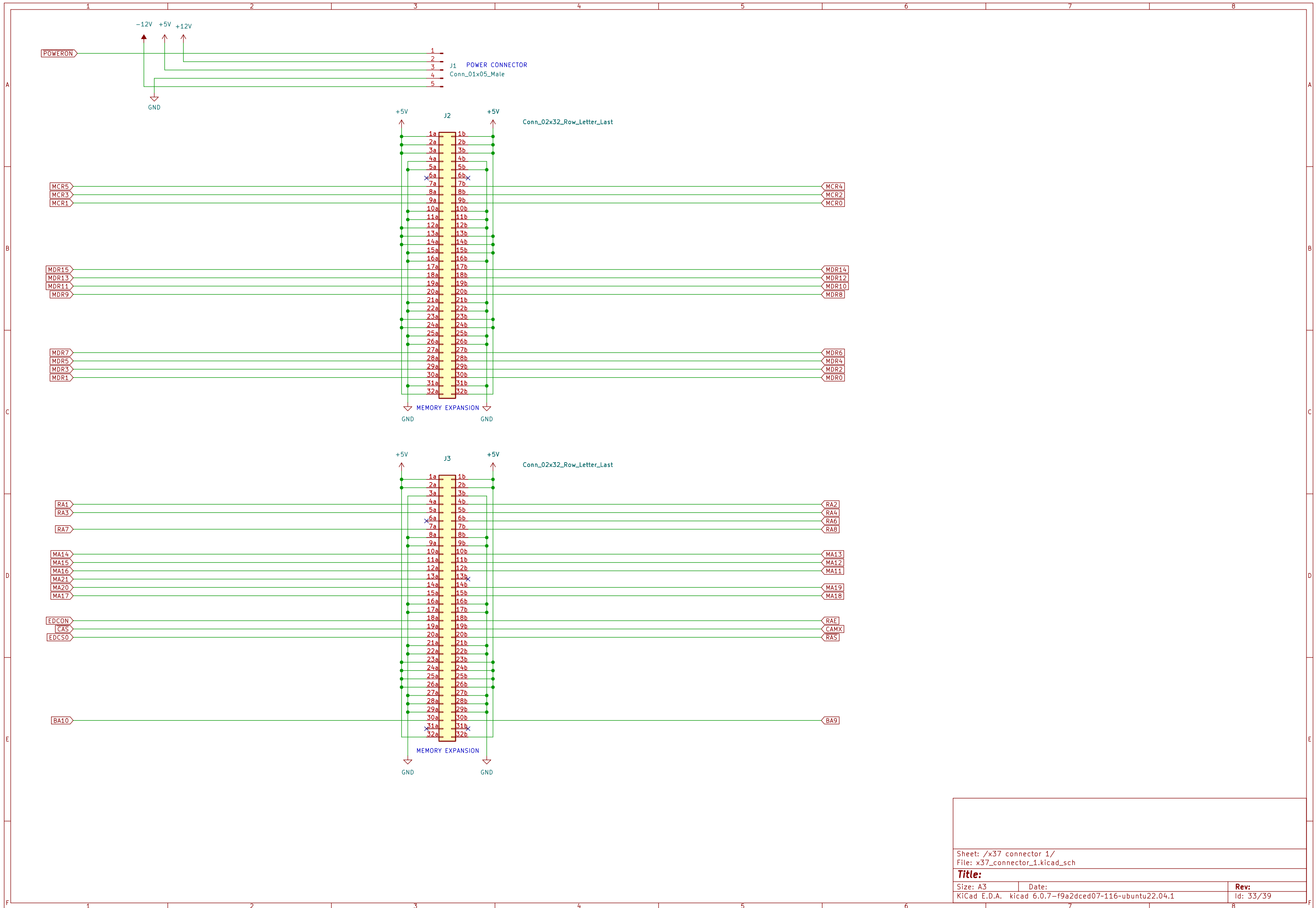

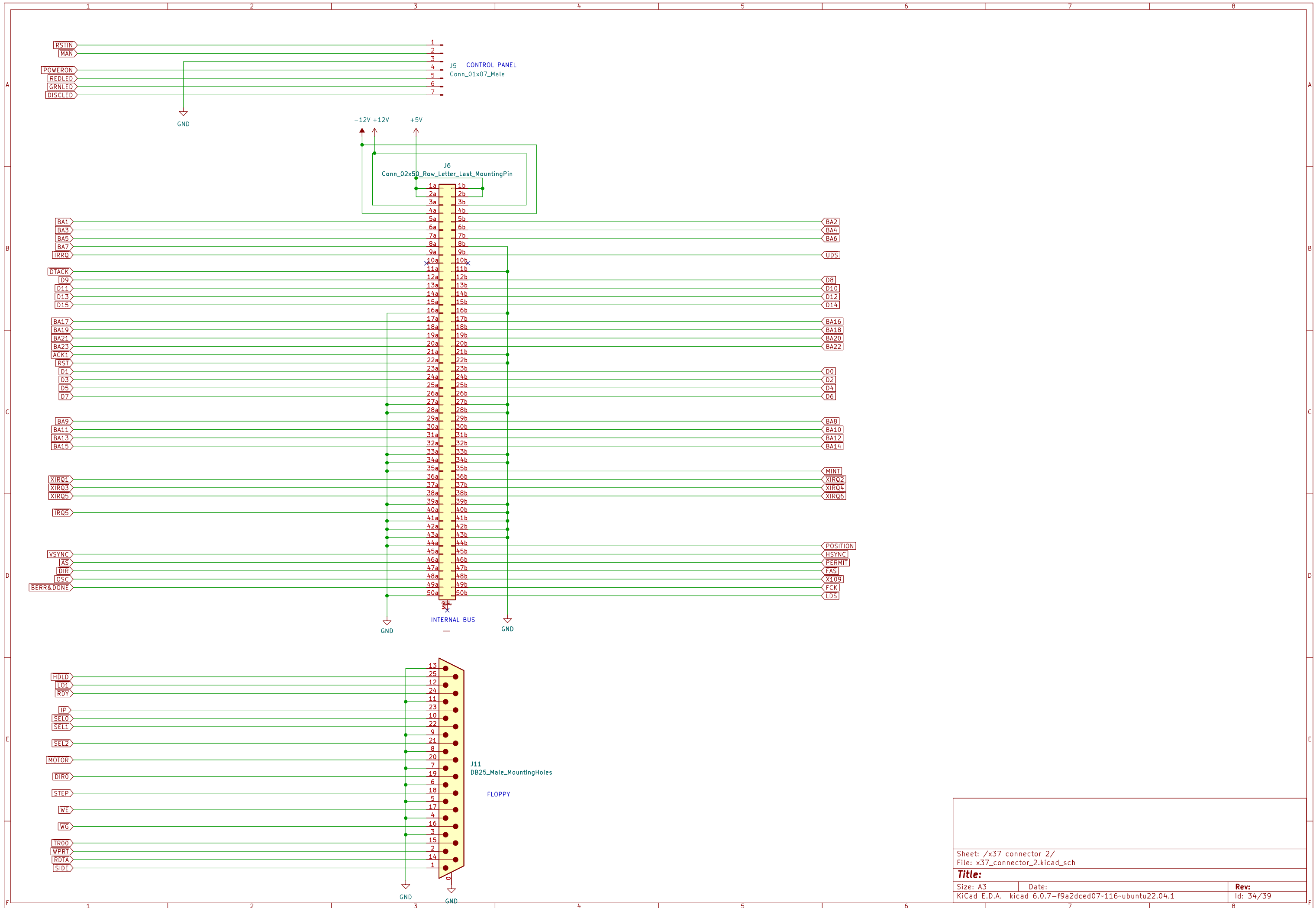

Sheet: /x37 connector 2/ File: x37_connector_2.kicad_sch		
<b>Title:</b>		
Size: A3	Date:	Rev:
KiCad E.D.A. kicad 6.0.7-f9a2dced07-116-ubuntu22.04.1		Id: 34/39

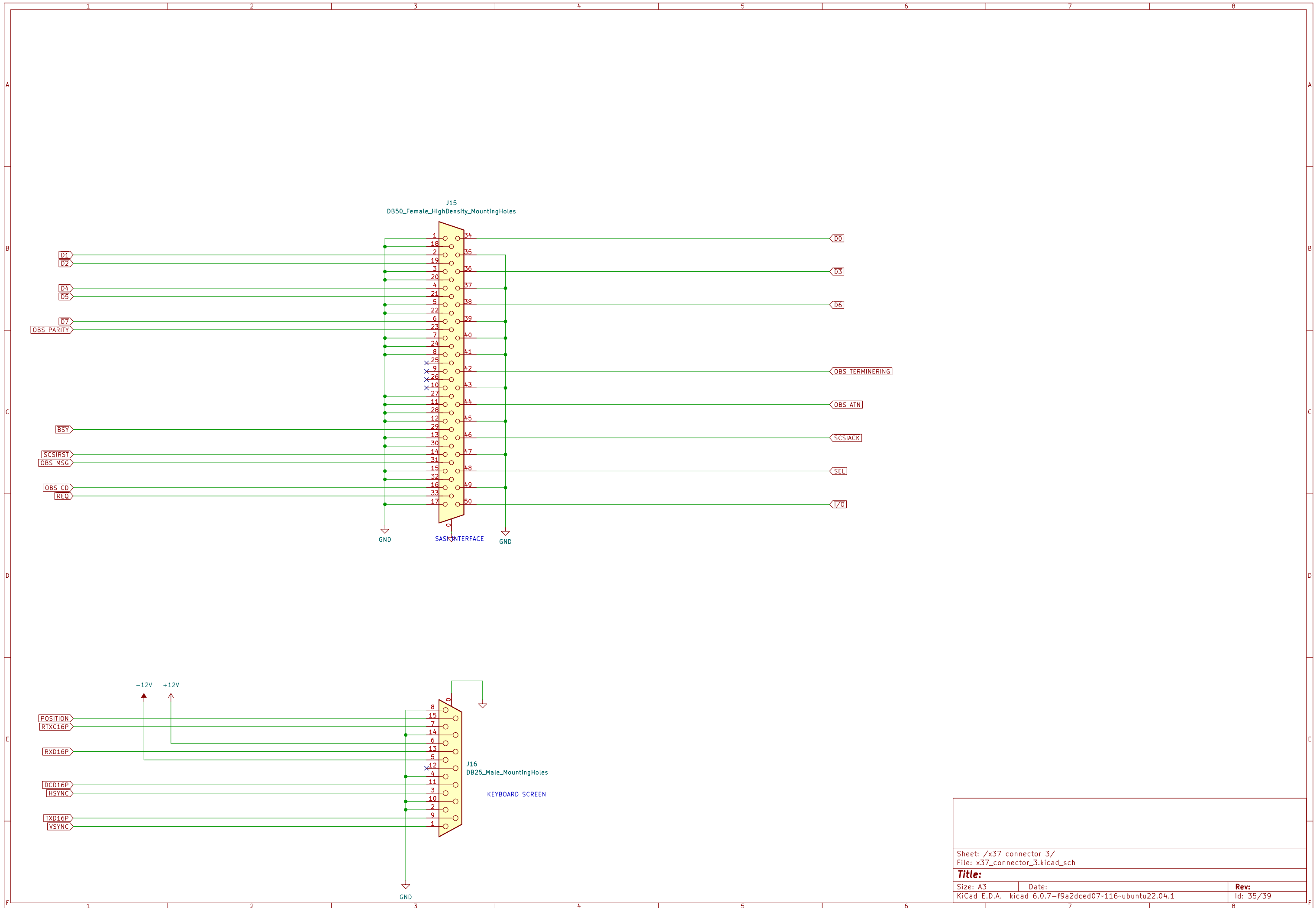

Sheet: /x37 connector 3/ File: x37_connector_3.kicad_sch		
<b>Title:</b>		
Size: A3	Date:	Rev:
KiCad E.D.A. kicad 6.0.7-f9a2dced07-116-ubuntu22.04.1		Id: 35/39

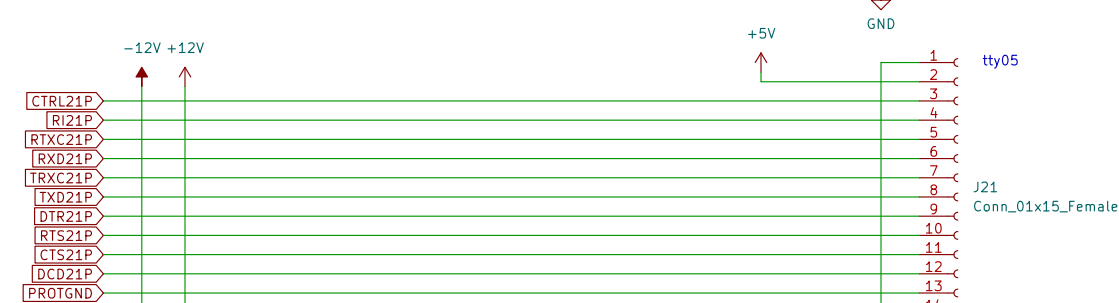
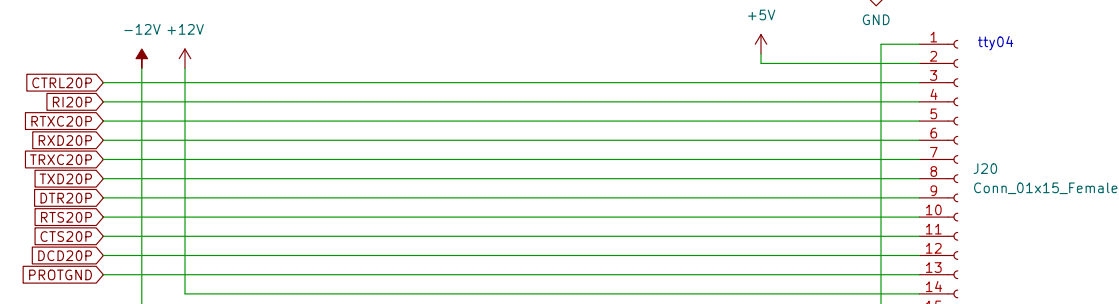
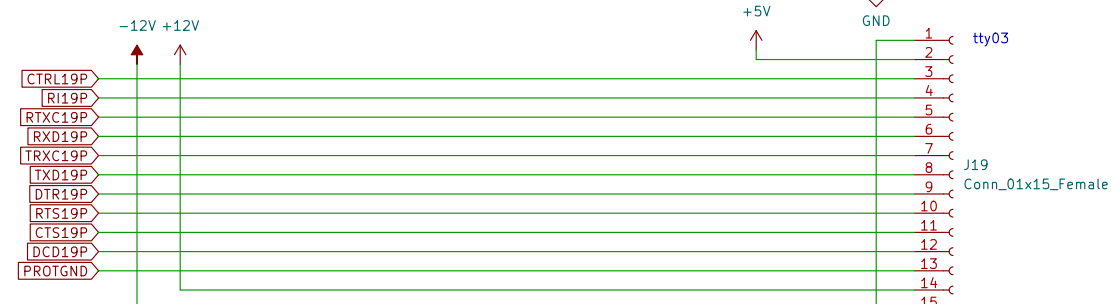
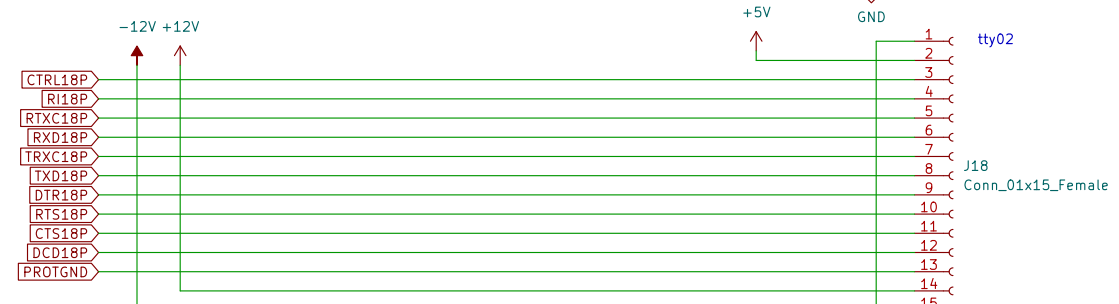
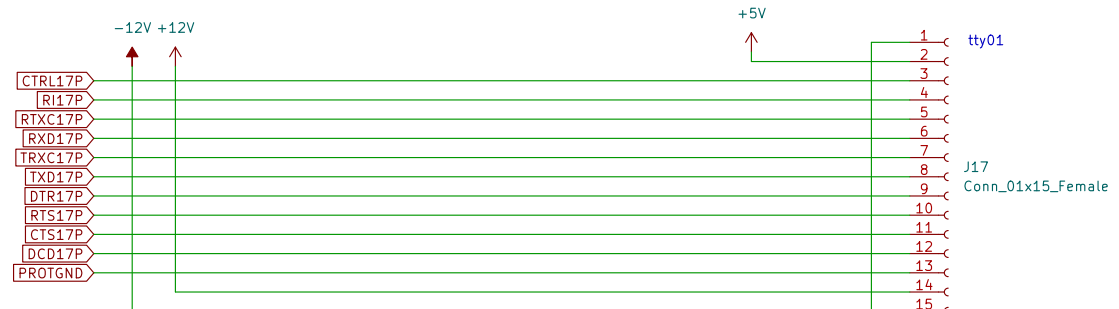

Sheet: /x37 connector 4/ File: x37_connector_4.kicad_sch		
<b>Title:</b>		
Size: A3	Date:	Rev:
KiCad E.D.A. kicad 6.0.7-f9a2dced07-116-ubuntu22.04.1		Id: 36/39

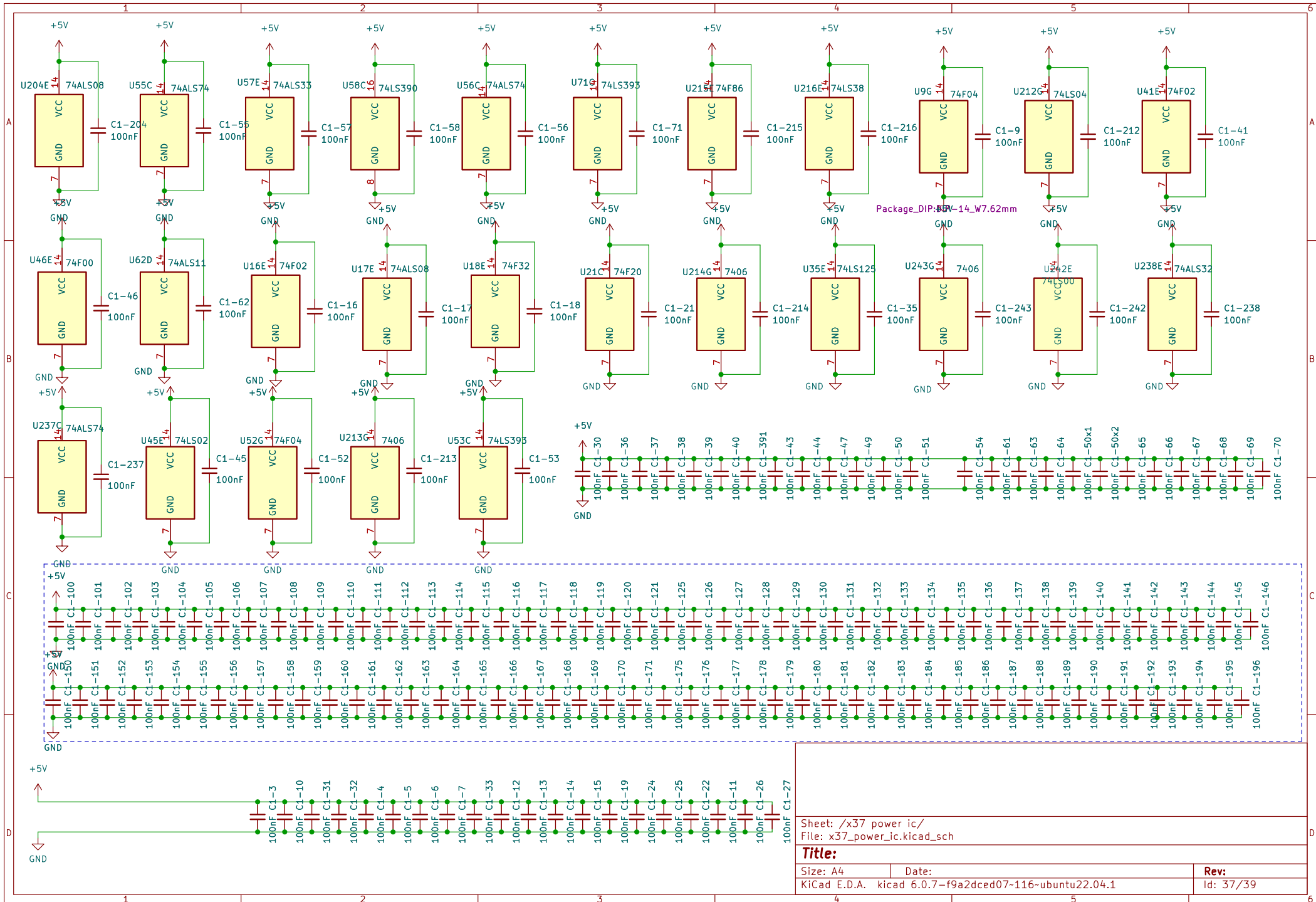

Sheet: /x37 power ic/  
 File: x37\_power\_ic.kicad\_sch

<b>Title:</b>	
Size: A4	Date:
KiCad E.D.A. kicad 6.0.7-f9a2dced07-116-ubuntu22.04.1	
Rev:	Id: 37/39

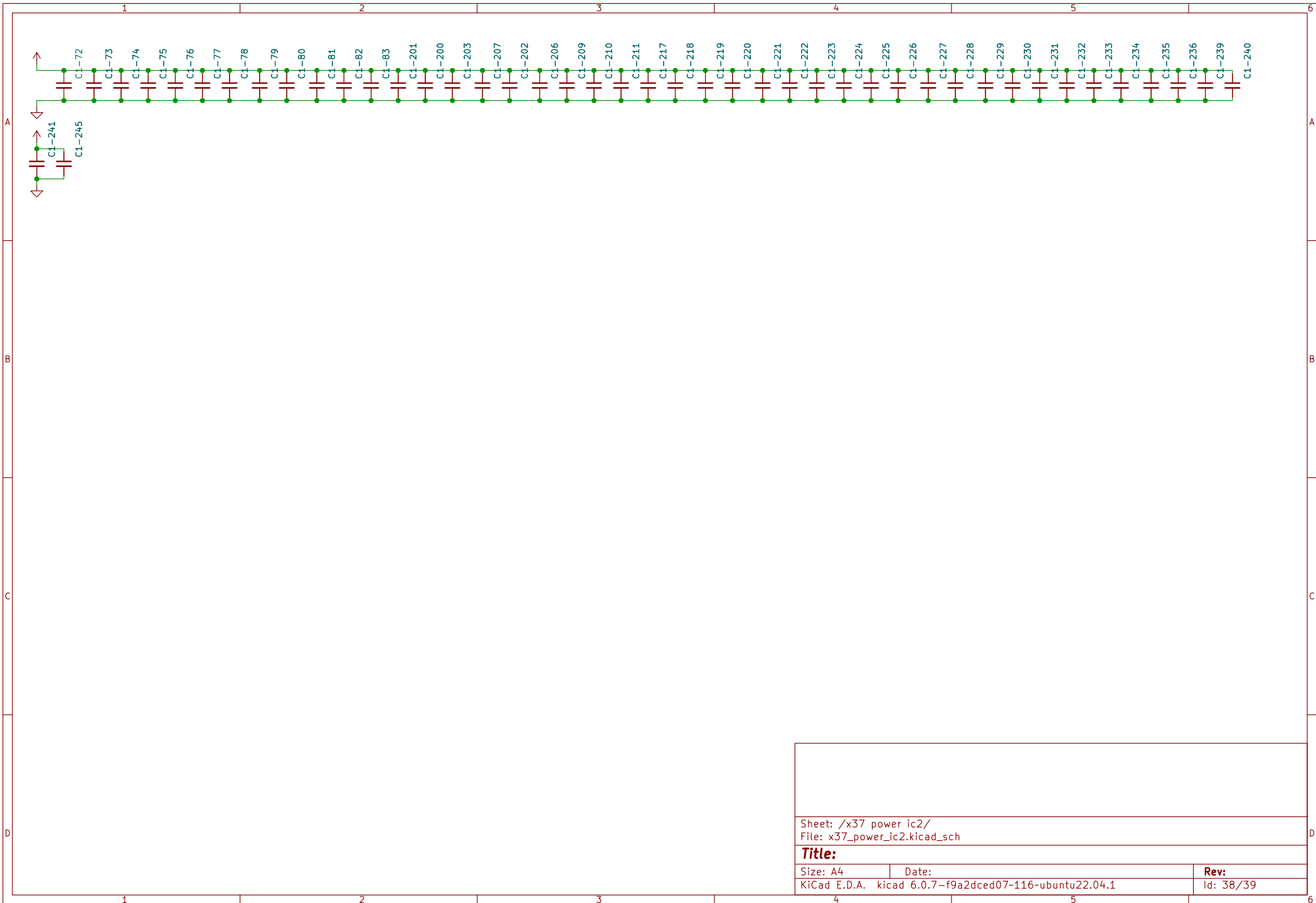



Sheet: /x37 fix for check/		
File: x37_fix_for_check.kicad_sch		
<b>Title:</b>		
Size: A4	Date:	<b>Rev:</b>
KiCad E.D.A. kicad 6.0.7-f9a2dced07-116-ubuntu22.04.1		Id: 39/39